

EDITION 14



# HAND TOOLS & POWER TOOL ACCESSORIES

CATALOGUE 2025/26



**CASTLE  
BROOKE**  
TOOLS (UK) LIMITED



i

### Delivery Terms:

Minimum order value £15.00 if order below an additional £2.50 charge.

Minimum carriage paid order £75.00 net next day for UK mainland. Under £75.00 net £8.25 next day.

For Hammer & Breaker Steels minimum carriage paid order £100.00 net next day.

For Northern Ireland/Channel Islands/Isle of Man/Wight/Islands and Highlands of Scotland £24.50 delivery 2 days. Minimum carriage paid order £150.00 net.

Non-mainland UK minimum carriage paid order £250.00 net.

Any products over 1 metre when packaged, will incur a surcharge. Please contact us for more information.

Timed deliveries please contact us on +44 (0)114 261 7200 or email [info@castlebrooke.co.uk](mailto:info@castlebrooke.co.uk)

All prices shown are exclusive of VAT.

# Contents



## Metal Drilling

HSS-G Jobber Drills	1-4
Cutting Oil	2
HSS-R & HSS-G Drill Sets, HSS Tap & Drill Sets	5
HSS-G Long Series Drills	6
HSS-G TiN Coated Jobber Drills	7
HSS Blacksmith Drills - Reduced Shank	8
HSS-Co5 Cobalt Jobbers & Long Series Drills	9-13
HSS-Co5 Cobalt Jobber Drill Sets	10
HSS-Co5 1/4" Quick-Change Drill Bits	13
HSS-Co5 Cobalt Blacksmith Drills - Reduced Shank	14
HSS Rotabor Cutters	15
HSS Centre, Step & Taper Drills	16
TCT Precision Drills	17



## Multi-Purpose Drilling

1/4" Quick-Change Multi-Purpose Drill Bits	14
--	----



## Masonry Drilling

Tile & Glass Drills & Set	17
Vacuum Brazed Diamond Tile Core Drills	18
Masonry Drills - Straight Shank	19-20
Masonry Drill Sets	20
SDS Plus Hammer Drills Bits & Sets	21-23
SDS Plus Quad Drill Bits	24
SDS Plus Rebar Cutters	24
SDS Max Hammer Drill Bits & Quick Fit Adaptor	25
Heavy Duty TCT Core Drills & Adaptors	26



## Hammer Breaker Steels

SDS Plus	28
SDS Max	28
Kango 900/950K	29
Bosch 11304/GSH27	29
Hilti TE905, TE1000 & TE2000	30
Hilti TE3000 & TE3000 Quick Change	30
Makita 8035NB/HM0810	30
Hitachi PH65A & Makita HM1317C	31
Accessories	31
Hexagon Shank 19x50mm (3/4" x 2")	32
Hexagon Shank 22x82mm (7/8" x 3.1/4")	32
Hexagon Shank 25x108mm (1" x 4.1/4")	33
Hexagon Shank 28x160mm (1.1/8" x 6.1/4")	33
Hexagon Shank 32x160mm (1.1/4" x 6.1/4")	34
Picking Hammers SK12, FL12 & CP9	34



## Wood Drilling

Wood Auger Bits & Sets	35
Flat Bits - Triple points & Sets	36
Centre Spur Wood Drills & Sets	37
Forstner Bits & Sets	37
Triple Fluted Wood Drills	38
TCT Router Bit & 1/4" Quick-Change Countersink Drill Bits	38



## Saws & Blades

Multi Tool Saw Blades & Accessories	39
HSS-Co8 Sheet Steel Holesaws, Arbor & Set	40
HSS, HSS-Co8 BIM & TCT Holesaws, Arbors & Sets	41-43
Morse Holesaws & Arbors	44-45
Power Planer Blades	45
Jigsaw Blades	46
Reciprocating Saw Blades & Scraper	46-47
Hacksaw Frames & Blades	48
Trimming Knife & Blades	48



## Other Hand Tools & Power Tool Accessories

Cold Chisels & Bolster	50
Scutch Comb Holders & Combs	50
Wrecking Bars, Pry Bar & Crow Bars	50
Drill Chucks & Adaptors	51
Industrial Wire Bushes	52
Tungsten Carbide Grit Mortar Rake	52
Drywall Sanding Discs	53
Riveting Pliers & Rivets	54
Screwdriver Bits & Bit Holders	55-56
Screw Extractor Set	56
63Pc Combination Drill & Drive Bit Set	56
Magnetic Nut Setters, Bi-Hex Tek Adaptor	57
Pro Power Tape Measures	57
Cartridge Drive Pins Consumables	58
Heavy Duty Hasps & Staples	59
Brass Padlocks, Space Lock & Armored Block Lock	59

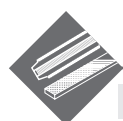

## Engineering

Carbide Burrs - Double Cut	60
HSS Taps & Dies	61-62
Tap Wrenches	63
Die Stock holders	63
Calipers & Dividers	64
Engineers Files & Rasps	65-68
Drive Pin Punches	69
Centre Punches	69
Steel Squares	69
Stainless Steel Rules	69
Letter & Number Stamps	70
Scribers	70
Hex Keys & Sets	71-72
Adjustable Hand Reamers	72



Personal Protective Equipment (PPE)	73-74
-------------------------------------	-------



Merchandisers	75-77
---------------	-------

+44 (0)114 261 7200  
info@castlebrooke.co.uk

www.castlebrooke.co.uk





# HSS-G Jobber Drill Bits

## SUITABLE FOR

Drilling alloyed and non-alloyed steel up to a tensile strength of 900N/MM<sup>2</sup>, cast steel, cast iron, non-ferrous metal and plastics.

## KEY FEATURES

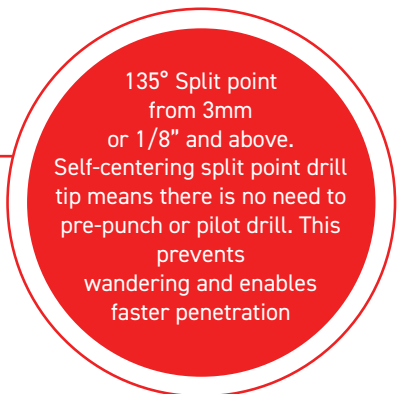

135° Split point from 3mm or 1/8" and above. Self-centering split point drill tip means there is no need to pre-punch or pilot drill. This prevents wandering and enables faster penetration

## RECOMMENDED TAPPING & DRILL SIZES

TAP	DRILL
M3	- 2.50mm
M4	- 3.30mm
M5	- 4.20mm
M6	- 5.00mm
M8	- 6.80mm
M10	- 8.50mm
M12	- 10.20mm
M14	- 12.00mm

- ◆ **Manufactured to DIN 338**
- ◆ **M2 High Speed Steel**
- ◆ **Ground Flutes**
- ◆ **Blue Oxide Finish**



CODE	DIAMETER	WORKING LENGTH	OVERALL LENGTH	PACK QTY	DISCOUNT GROUP
C101-0010	1.00mm	12mm	34mm	10	R
C101-0015	1.50mm	18mm	40mm	10	R
C101-0020	2.00mm	24mm	49mm	10	R
C101-0025	2.50mm	30mm	57mm	10	R
C101-0030	3.00mm	33mm	61mm	10	R
C101-0032	3.20mm	36mm	65mm	10	R
C101-0033	3.30mm	36mm	65mm	10	R
C101-0035	3.50mm	39mm	70mm	10	R
C101-0040	4.00mm	43mm	75mm	10	R
C101-0042	4.20mm	43mm	75mm	10	R
C101-0045	4.50mm	47mm	80mm	10	R
C101-0048	4.80mm	52mm	86mm	10	R
C101-0050	5.00mm	52mm	86mm	10	R
C101-0055	5.50mm	57mm	93mm	10	R
C101-0060	6.00mm	57mm	93mm	10	R
C101-0065	6.50mm	63mm	101mm	10	R
C101-0068	6.80mm	63mm	101mm	10	R
C101-0070	7.00mm	63mm	101mm	10	R
C101-0075	7.50mm	69mm	109mm	10	R
C101-0080	8.00mm	75mm	117mm	10	R
C101-0085	8.50mm	75mm	117mm	10	R
C101-0090	9.00mm	81mm	125mm	10	R
C101-0095	9.50mm	81mm	125mm	10	R
C101-0100	10.00mm	87mm	133mm	5	R
C101-0102	10.20mm	87mm	133mm	5	R
C101-0105	10.50mm	94mm	142mm	5	R
C101-0110	11.00mm	94mm	142mm	5	R
C101-0115	11.50mm	94mm	142mm	5	R
C101-0120	12.00mm	101mm	151mm	5	R
C101-0125	12.50mm	101mm	151mm	5	R
C101-0130	13.00mm	101mm	151mm	5	R

Please contact us for more drill sizes  
+44 (0)114 261 7200  
info@castlebrooke.co.uk



# HSS-G Jobber Drill Bits



CODE	DIAMETER	WORKING LENGTH	OVERALL LENGTH	PACK QTY	DISCOUNT GROUP
C101-1001	1/64"	5mm	20mm	10	R
C101-1002	1/32 "	10mm	30mm	10	R
C101-1003	3/64 "	16mm	38mm	10	R
C101-1004	1/16 "	20mm	43mm	10	R
C101-1005	5/64 "	24mm	49mm	10	R
C101-1006	3/32 "	30mm	57mm	10	R
C101-1007	7/64 "	33mm	61mm	10	R
C101-1008	1/8 "	36mm	65mm	10	R
C101-1009	9/64 "	39mm	70mm	10	R
C101-1010	5/32 "	43mm	75mm	10	R
C101-1011	11/64 "	47mm	80mm	10	R
C101-1012	3/16 "	52mm	86mm	10	R
C101-1013	13/64 "	52mm	86mm	10	R
C101-1014	7/32 "	57mm	93mm	10	R
C101-1015	15/64 "	57mm	93mm	10	R
C101-1016	1/4 "	63mm	101mm	10	R
C101-1017	17/64 "	69mm	109mm	10	R
C101-1018	9/32 "	69mm	109mm	10	R
C101-1019	19/64 "	75mm	117mm	10	R
C101-1020	5/16 "	75mm	117mm	10	R
C101-1021	21/64 "	75mm	117mm	10	R
C101-1022	11/32 "	81mm	125mm	10	R
C101-1023	23/64 "	81mm	125mm	10	R
C101-1024	3/8 "	87mm	133mm	10	R
C101-1025	25/64 "	87mm	133mm	5	R
C101-1026	13/32 "	87mm	133mm	5	R
C101-1027	27/64 "	94mm	142mm	5	R
C101-1028	7/16 "	94mm	142mm	5	R
C101-1029	29/64 "	94mm	142mm	5	R
C101-1030	15/32 "	101mm	151mm	5	R
C101-1031	31/64 "	101mm	151mm	5	R
C101-1032	1/2 "	101mm	151mm	5	R



PACKAGING TYPE

Drilling & Cutting  
Lubricant 400ml

CODE	PACK QTY
84010	1

Available in box qty of 12 x 400ml



STEEL



CAST IRON



NON-FERROUS  
METAL



PLASTIC



# HSS-G Jobber Drills - Walled

## SUITABLE FOR

Drilling alloyed and non-alloyed steel up to a tensile strength of 900N/MM<sup>2</sup>, cast steel, cast iron, non ferrous metal and plastics.

## KEY FEATURES



135° Split point from 3mm or 1/8" and above. Self-centering split point drill tip means there is no need to pre-punch or pilot drill. This prevents wandering and enables faster penetration

### RECOMMENDED TAPPING & DRILL SIZES

TAP	DRILL
M3	- 2.50mm
M4	- 3.30mm
M5	- 4.20mm
M6	- 5.00mm
M8	- 6.80mm
M10	- 8.50mm
M12	- 10.20mm
M14	- 12.00mm

- ◆ **Manufactured to DIN 338**
- ◆ **M2 High Speed Steel**
- ◆ **Ground Flutes**
- ◆ **Blue Oxide Finish**

CODE	DIAMETER	WORKING LENGTH	OVERALL LENGTH	PACK QTY	DISCOUNT GROUP
C101-0010W	1.00mm	12mm	34mm	1	R
C101-0015W	1.50mm	18mm	40mm	1	R
C101-0020W	2.00mm	24mm	49mm	1	R
C101-0025W	2.50mm	30mm	57mm	1	R
C101-0030W	3.00mm	33mm	61mm	1	R
C101-0032W	3.20mm	36mm	65mm	1	R
C101-0033W	3.30mm	36mm	65mm	1	R
C101-0035W	3.50mm	39mm	70mm	1	R
C101-0040W	4.00mm	43mm	75mm	1	R
C101-0042W	4.20mm	43mm	75mm	1	R
C101-0045W	4.50mm	47mm	80mm	1	R
C101-0048W	4.80mm	52mm	86mm	1	R
C101-0050W	5.00mm	52mm	86mm	1	R
C101-0055W	5.50mm	57mm	93mm	1	R
C101-0060W	6.00mm	57mm	93mm	1	R
C101-0065W	6.50mm	63mm	101mm	1	R
C101-0068W	6.80mm	63mm	101mm	1	R
C101-0070W	7.00mm	63mm	101mm	1	R
C101-0075W	7.50mm	69mm	109mm	1	R
C101-0080W	8.00mm	75mm	117mm	1	R
C101-0085W	8.50mm	75mm	117mm	1	R
C101-0090W	9.00mm	81mm	125mm	1	R
C101-0095W	9.50mm	81mm	125mm	1	R
C101-0100W	10.00mm	87mm	133mm	1	R
C101-0102W	10.20mm	87mm	133mm	1	R
C101-0105W	10.50mm	94mm	142mm	1	R
C101-0110W	11.00mm	94mm	142mm	1	R
C101-0115W	11.50mm	94mm	142mm	1	R
C101-0120W	12.00mm	101mm	151mm	1	R
C101-0125W	12.50mm	101mm	151mm	1	R
C101-0130W	13.00mm	101mm	151mm	1	R

See page 2 for cutting oil

Please contact us for more drill sizes  
+44 (0)114 261 7200  
info@castlebrooke.co.uk

# HSS-G Jobber Drills - Walled



CODE	DIAMETER	WORKING LENGTH	OVERALL LENGTH	PACK QTY	DISCOUNT GROUP
C101-1003W	3/64 "	16mm	38mm	1	R
C101-1004W	1/16 "	20mm	43mm	1	R
C101-1005W	5/64 "	24mm	49mm	1	R
C101-1006W	3/32 "	30mm	57mm	1	R
C101-1007W	7/64 "	33mm	61mm	1	R
C101-1008W	1/8 "	36mm	65mm	1	R
C101-1009W	9/64 "	39mm	70mm	1	R
C101-1010W	5/32 "	43mm	75mm	1	R
C101-1011W	11/64 "	47mm	80mm	1	R
C101-1012W	3/16 "	52mm	86mm	1	R
C101-1013W	13/64 "	52mm	86mm	1	R
C101-1014W	7/32 "	57mm	93mm	1	R
C101-1015W	15/64 "	57mm	93mm	1	R
C101-1016W	1/4 "	63mm	101mm	1	R
C101-1017W	17/64 "	69mm	109mm	1	R
C101-1018W	9/32 "	69mm	109mm	1	R
C101-1019W	19/64 "	75mm	117mm	1	R
C101-1020W	5/16 "	75mm	117mm	1	R
C101-1021W	21/64 "	75mm	117mm	1	R
C101-1022W	11/32 "	81mm	125mm	1	R
C101-1023W	23/64 "	81mm	125mm	1	R
C101-1024W	3/8 "	87mm	133mm	1	R
C101-1025W	25/64 "	87mm	133mm	1	R
C101-1026W	13/32 "	87mm	133mm	1	R
C101-1027W	27/64 "	94mm	142mm	1	R
C101-1028W	7/16 "	94mm	142mm	1	R
C101-1029W	29/64 "	94mm	142mm	1	R
C101-1030W	15/32 "	101mm	151mm	1	R
C101-1031W	31/64 "	101mm	151mm	1	R
C101-1032W	1/2 "	101mm	151mm	1	R

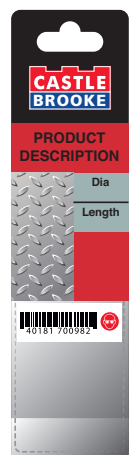

PACKAGING TYPE



STEEL



CAST IRON



NON-FERROUS METAL



PLASTIC

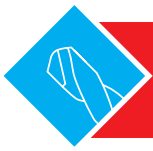

# HSS-R & HSS-G Drill Sets, HSS Tap & Drill Sets

CODE	DESCRIPTION & SIZE	PACK QTY	DISCOUNT GROUP
C109-0021	19Pc. 1.0 - 10.0mm x 0.5mm HSS-R Roll - Forged	1	R
C109-0020	25pc. 1.0 - 13.0mm x 0.5mm HSS-R Roll - Forged	1	R
C109-0022	29Pc. 1/16 - 1/2" x 1/64" HSS-R Roll - Forged	1	R
5195-0019	19Pc. 1.0 - 10.0mm x 0.5mm HSS-G	1	W
5195-0025	25Pc. 1.0 - 13.0mm x 0.5mm HSS-G	1	W
5195-0025BF	25Pc. 1.0 - 13.0mm x 0.5mm HSS-G Bright Finish	1	W
5103-0925	25Pc. 1.0 - 13.0mm x 0.5mm HSS-G Tin Coated	1	W
6380-0030	28Pc HSS Tap & HSS-G Drill Bits	1	W
6380-0031	28Pc HSS Tap & HSS-G Tin Coated Drill Bits	1	W
6380-0032	28Pc HSS Taps & HSS-Co5 Cobalt Drills Bits	1	W
5195-9170	170Pc HSS-G Jobber Drill Bit Set	1	W
5103-9170	170Pc HSS-G Tin Coated Jobber Drill Bit Set	1	W
5182-9170	170Pc HSS-Co5 Jobber Drill Bit Set	1	W



**170 Pc sets**  
**10 pc per size -**  
 1.0,1.5,2.0,2.5,3.0,3.5,4.0,4.5,  
 5.0, 5.5,6.0,6.5,7.0,7.5,8.0mm  
**5 pc per size -**  
 8.5,9.0,9.5,10.0mm



**Roll - Forged Drill Sets**  
 118° Point angle.



**Ground Flute Drill Sets**  
 135° Split point.

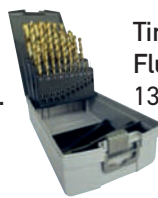

**Tin Coated Ground Flute Drill Sets**  
 135° Split point.



**28Pc HSS Tap & Drill Sets**  
 Taper Second. Bottom  
 M3,M4,M5,M6, M8,M10,M12  
 Drill sizes - 2, 5,3,3,4,2,5,  
 6,8, 8.5,10,2mm

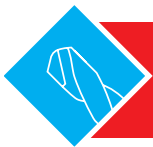

# HSS-G Combination Drill & Tap Bits

## SUITABLE FOR

Drilling alloyed and non-alloyed steel, cast steel, cast iron, non-ferrous metal and plastics.

## KEY FEATURES

◆ **M2 High Speed Steel**



## HSS-G COMBINATION DRILL & TAP + SET - Metric Course

CODE	DIAMETER & PITCH	OVERALL LENGTH	PACK QTY	DISCOUNT GROUP
5156-0030	M3.0x.50	36mm	1	W
5156-0040	M4.0x.70	39mm	1	W
5156-0050	M5.0x.80	41mm	1	W
5156-0060	M6.0x1.0	44mm	1	W
5156-0080	M8.0x1.25	50mm	1	W
5156-0100	M10.0x1.50	59mm	1	W
5156-0000	M3-M10 Combination Drill & Tap Set + Magnetic Bit Holder 7Pc		1	W

CASTLE BROOKE PRODUCT DESCRIPTION

PACKAGING TYPE

Please contact us for more drill sizes  
 +44 (0)114 261 7200  
 info@castlebrooke.co.uk



STEEL

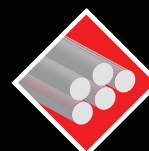

CAST IRON



NON-FERROUS METAL



PLASTIC



# HSS-G Long Series Drills - Boxed/Walleted

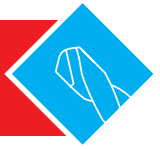

BOXED CODE	WALLETED CODE	DIAMETER	WORKING LENGTH	OVER-ALL LENGTH	BOXED PACK QTY	WALLETED PACK QTY	DISCOUNT GROUP
C106-0015	C106-0015W	1.50mm	45mm	70mm	10	1	R
C106-0020	C106-0020W	2.00mm	56mm	85mm	10	1	R
C106-0025	C106-0025W	2.50mm	62mm	95mm	10	1	R
C106-0030	C106-0030W	3.00mm	66mm	100mm	10	1	R
C106-0032	C106-0032W	3.20mm	69mm	106mm	10	1	R
C106-0035	C106-0035W	3.50mm	73mm	112mm	10	1	R
C106-0040	C106-0040W	4.00mm	78mm	119mm	10	1	R
C106-0042	C106-0042W	4.20mm	78mm	119mm	10	1	R
C106-0045	C106-0045W	4.50mm	82mm	126mm	10	1	R
C106-0048	C106-0048W	4.80mm	87mm	126mm	10	1	R
C106-0050	C106-0050W	5.00mm	87mm	132mm	10	1	R
C106-0055	C106-0055W	5.50mm	91mm	139mm	10	1	R
C106-0060	C106-0060W	6.00mm	91mm	139mm	10	1	R
C106-0065	C106-0065W	6.50mm	97mm	148mm	10	1	R
C106-0068	C106-0068W	6.80mm	102mm	156mm	10	1	R
C106-0070	C106-0070W	7.00mm	102mm	156mm	10	1	R
C106-0075	C106-0075W	7.50mm	102mm	156mm	10	1	R
C106-0080	C106-0080W	8.00mm	109mm	165mm	10	1	R
C106-0085	C106-0085W	8.50mm	109mm	165mm	10	1	R
C106-0090	C106-0090W	9.00mm	115mm	175mm	10	1	R
C106-0095	C106-0095W	9.50mm	115mm	175mm	10	1	R
C106-0100	C106-0100W	10.00mm	121mm	184mm	5	1	R
C106-0105	C106-0105W	10.50mm	121mm	184mm	5	1	R
C106-0110	C106-0110W	11.00mm	128mm	195mm	5	1	R
C106-0115	C106-0115W	11.50mm	128mm	195mm	5	1	R
C106-0120	C106-0120W	12.00mm	134mm	205mm	5	1	R
C106-0125	C106-0125W	12.50mm	134mm	205mm	5	1	R
C106-0130	C106-0030W	13.00mm	134mm	205mm	5	1	R
C106-0140	C106-0040W	14.00mm	140mm	214mm	1	1	R

## SUITABLE FOR

Drilling alloyed and non-alloyed steel up to a tensile strength of 900N/MM<sup>2</sup>, cast steel, cast iron, non-ferrous metal and plastics.

## KEY FEATURES

135° Split point from 3mm or 1/8" and above.  
Self-centering split point drill tip means there is no need to pre-punch or pilot drill.  
This prevents wandering and enables faster penetration



- ◆ **Manufactured to DIN 340**
- ◆ **M2 High Speed Steel**
- ◆ **Ground Flutes**
- ◆ **Blue Oxide Finish**



PACKAGING TYPES

See page 2 for cutting oil



STEEL



CAST IRON



NON-FERROUS METAL



PLASTIC



# HSS-G TiN Coated Jobber Drills - Boxed/Walleted

## SUITABLE FOR

Drilling alloyed and non-alloyed steel up to tensile strength of 900N/mm<sup>2</sup>, cast steel, cast iron, non ferrous metal and plastics.

## KEY FEATURES

135° split point from 3mm and above. Compared to traditional HSS jobber drill bits, speed can be increased by 40 - 60% and feed by 10 -20% without reducing the life time of the drill bit significantly.

TiN is also a poor conductor of heat, so the heat generated during the drilling process is diverted into the chips and coolant and less into the drill bit.

## RECOMMENDED TAPPING & DRILL SIZES

TAP	DRILL
M3	- 2.50mm
M4	- 3.30mm
M5	- 4.20mm
M6	- 5.00mm
M8	- 6.80mm
M10	- 8.50mm
M12	- 10.20mm
M14	- 12.00mm

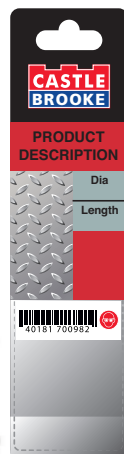

PACKAGING TYPES

CODE BOXED	CODE WALLETED	DIAMETER	WORKING LENGTH	OVERALL LENGTH	BOX QTY	WALLET QTY	DISCOUNT GROUP
C105-0010	C105-0010W	1.00mm	12mm	34mm	10	1	R
C105-0015	C105-0015W	1.50 mm	18mm	40mm	10	1	R
C105-0020	C105-0020W	2.00 mm	24mm	49mm	10	1	R
C105-0025	C105-0025W	2.50 mm	30mm	57mm	10	1	R
C105-0030	C105-0030W	3.00 mm	33mm	61mm	10	1	R
C105-0032	C105-0032W	3.20 mm	36mm	65mm	10	1	R
C105-0033	C105-0033W	3.30 mm	36mm	65mm	10	1	R
C105-0035	C105-0035W	3.50 mm	39mm	70mm	10	1	R
C105-0040	C105-0040W	4.00 mm	43mm	75mm	10	1	R
C105-0042	C105-0042W	4.20 mm	43mm	75mm	10	1	R
C105-0045	C105-0045W	4.50 mm	47mm	80mm	10	1	R
C105-0048	C105-0048W	4.80 mm	52mm	86mm	10	1	R
C105-0050	C105-0050W	5.00 mm	52mm	86mm	10	1	R
C105-0055	C105-0055W	5.50 mm	57mm	93mm	10	1	R
C105-0060	C105-0060W	6.00 mm	57mm	93mm	10	1	R
C105-0065	C105-0065W	6.50 mm	63mm	101mm	10	1	R
C105-0068	C105-0068W	6.80 mm	63mm	101mm	10	1	R
C105-0070	C105-0070W	7.00 mm	63mm	101mm	10	1	R
C105-0075	C105-0075W	7.50 mm	69mm	109mm	10	1	R
C105-0080	C105-0080W	8.00 mm	75mm	117mm	10	1	R
C105-0085	C105-0085W	8.50 mm	75mm	117mm	10	1	R
C105-0090	C105-0090W	9.00 mm	81mm	125mm	10	1	R
C105-0095	C105-0095W	9.50 mm	81mm	125mm	10	1	R
C105-0100	C105-0100W	10.00 mm	87mm	133mm	5	1	R
C105-0102	C105-0102W	10.20 mm	87mm	133mm	5	1	R
C105-0105	C105-0105W	10.50 mm	94mm	142mm	5	1	R
C105-0110	C105-0110W	11.00 mm	94mm	142mm	5	1	R
C105-0115	C105-0115W	11.50 mm	94mm	142mm	5	1	R
C105-0120	C105-0120W	12.00 mm	101mm	151mm	5	1	R
C105-0125	C105-0125W	12.50 mm	101mm	151mm	5	1	R
C105-0130	C105-0130W	13.00 mm	101mm	151mm	5	1	R

- ◆ **Manufactured to DIN 338**
- ◆ **M2 High Speed Steel**
- ◆ **Ground Flutes**
- ◆ **TiN Coated Finish**



STEEL

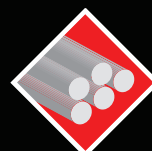

CAST IRON



NON-FERROUS METAL



PLASTIC

+44 (0)114 261 7200  
info@castlebrooke.co.uk



# HSS Blacksmith Drills

## SUITABLE FOR

Drilling alloyed and non-alloyed steel up to a tensile strength of 900N/MM<sup>2</sup>, cast steel, cast iron, non-ferrous metal and plastics.

## RECOMMENDED TAPPING & DRILL SIZES

TAP	DRILL
M16 - 14.00mm	M18 - 15.50mm
M20 - 17.50mm	M22 - 19.50mm
M24 - 21.00mm	



## KEY FEATURES

118° point angle

Reduced shank to 1/2" this means drill bits larger than 13mm can be used in a 1/2" chuck.

- ◆ **M2 High Speed Steel**
- ◆ **Milled flutes**
- ◆ **Blue oxide finish with bright margins**

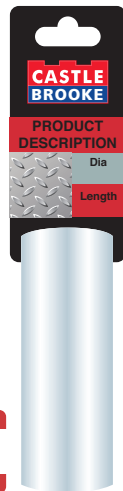

PACKAGING TYPES - PLEASE SPECIFY

CODE	DIAMETER	WORKING LENGTH	OVERALL LENGTH	PACK QTY	DISCOUNT GROUP
C103-0130	13.0mm	80mm	152mm	1	R
C103-0135	13.5mm	80mm	152mm	1	R
C103-0140	14.0mm	80mm	152mm	1	R
C103-0145	14.5mm	80mm	152mm	1	R
C103-0150	15.0mm	80mm	152mm	1	R
C103-0155	15.5mm	80mm	152mm	1	R
C103-0160	16.0mm	80mm	152mm	1	R
C103-0165	16.5mm	80mm	152mm	1	R
C103-0170	17.0mm	80mm	152mm	1	R
C103-0175	17.5mm	80mm	152mm	1	R
C103-0180	18.0mm	80mm	152mm	1	R
C103-0185	18.5mm	80mm	152mm	1	R
C103-0190	19.0mm	80mm	152mm	1	R
C103-0195	19.5mm	76mm	152mm	1	R
C103-0200	20.0mm	76mm	152mm	1	R
C103-0210	21.0mm	76mm	152mm	1	R
C103-0220	22.0mm	76mm	152mm	1	R
C103-0230	23.0mm	76mm	152mm	1	R
C103-0240	24.0mm	76mm	152mm	1	R
C103-0250	25.0mm	76mm	152mm	1	R
C103-1034	17/32 "	80mm	152mm	1	R
C103-1036	9/16 "	80mm	152mm	1	R
C103-1038	19/32 "	80mm	152mm	1	R
C103-1040	5/8 "	80mm	152mm	1	R
C103-1042	21/32 "	80mm	152mm	1	R
C103-1044	11/16 "	80mm	152mm	1	R
C103-1046	23/32 "	80mm	152mm	1	R
C103-1048	3/4 "	76mm	152mm	1	R
C103-1050	25/32 "	76mm	152mm	1	R
C103-1052	13/16 "	76mm	152mm	1	R
C103-1056	7/8 "	76mm	152mm	1	R
C103-1058	29/32 "	76mm	152mm	1	R
C103-1060	15/16 "	76mm	152mm	1	R
C103-1100	1 "	76mm	152mm	1	R
C103-1108	1.1/8 "	76mm	152mm	1	R
C103-1116	1.1/4 "	76mm	152mm	1	R
C103-1999	14.5, 16.0, 19.0, 22.0, 25.0mm - 5Pc Set			1	R

See page 2 for cutting oil

+44 (0)114 261 7200  
info@castlebrooke.co.uk



STEEL



CAST IRON



NON-FERROUS METAL



PLASTIC

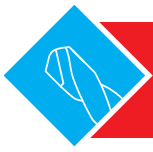

# HSS-Co5 Cobalt Drills

## SUITABLE FOR

Drilling alloyed and non-alloyed steel up to a tensile strength of 1000N/mm<sup>2</sup>, stainless steel V2A/V4A, cast steel, cast iron, acid and heat resistant steels.

## KEY FEATURES



135° Split point from 3mm or 1/8" and above. Self-centering split point drill tip means there is no need to pre-punch or pilot drill. This prevents wandering and enables faster penetration

### TAPPING SIZES

- TAP DRILL
- M3 - 2.50mm
  - M4 - 3.30mm
  - M5 - 4.20mm
  - M6 - 5.00mm
  - M8 - 6.80mm
  - M10 - 8.50mm
  - M12 - 10.20mm
  - M14 - 12.00mm

- ◆ **Manufactured to DIN 338**
- ◆ **M35 (5% cobalt)**
- ◆ **Ground flutes**
- ◆ **Straw finish**



PACKAGING TYPE

CODE	DIAMETER	WORKING LENGTH	OVERALL LENGTH	PACK QTY	DISCOUNT GROUP
C107-0010	1.0mm	12mm	34mm	10	R
C107-0015	1.5mm	18mm	40mm	10	R
C107-0020	2.0mm	24mm	49mm	10	R
C107-0025	2.5mm	30mm	57mm	10	R
C107-0030	3.0mm	33mm	61mm	10	R
C107-0032	3.2mm	36mm	65mm	10	R
C107-0033	3.3mm	36mm	65mm	10	R
C107-0035	3.5mm	39mm	70mm	10	R
C107-0040	4.0mm	43mm	75mm	10	R
C107-0042	4.2mm	43mm	75mm	10	R
C107-0045	4.5mm	47mm	80mm	10	R
C107-0048	4.8mm	52mm	86mm	10	R
C107-0050	5.0mm	52mm	86mm	10	R
C107-0055	5.5mm	57mm	93mm	10	R
C107-0060	6.0mm	57mm	93mm	10	R
C107-0065	6.5mm	63mm	101mm	10	R
C107-0068	6.8mm	63mm	101mm	10	R
C107-0070	7.0mm	63mm	101mm	10	R
C107-0075	7.5mm	69mm	109mm	10	R
C107-0080	8.0mm	75mm	117mm	10	R
C107-0085	8.5mm	75mm	117mm	10	R
C107-0090	9.0mm	81mm	125mm	10	R
C107-0095	9.5mm	81mm	125mm	10	R
C107-0100	10.0mm	87mm	133mm	5	R
C107-0102	10.2mm	87mm	133mm	5	R
C107-0105	10.5mm	94mm	142mm	5	R
C107-0110	11.0mm	94mm	142mm	5	R
C107-0115	11.5mm	94mm	142mm	5	R
C107-0120	12.0mm	101mm	151mm	5	R
C107-0125	12.5mm	101mm	151mm	5	R
C107-0130	13.0mm	101mm	151mm	5	R

HSS-Co5 COBALT DRILLS					
CODE	DIAMETER IMPERIAL	WORKING LENGTH	OVERALL LENGTH	PACK QTY	DISCOUNT GROUP
C107-1004	1/16 "	20mm	43mm	10	R
C107-1005	5/64 "	24mm	49mm	10	R
C107-1006	3/32 "	30mm	57mm	10	R
C107-1007	7/64 "	33mm	61mm	10	R
C107-1008	1/8 "	36mm	65mm	10	R
C107-1009	9/64 "	39mm	70mm	10	R
C107-1010	5/32 "	43mm	75mm	10	R

Please contact us for more drill sizes  
 +44 (0)114 261 7200  
 info@castlebrooke.co.uk

# HSS-Co5 Cobalt Drills



CODE	DIAMETER	WORKING LENGTH	OVERALL LENGTH	PACK QTY	DISCOUNT GROUP
C107-1011	11/64 "	47mm	80mm	10	R
C107-1012	3/16 "	52mm	86mm	10	R
C107-1013	13/64 "	52mm	86mm	10	R
C107-1014	7/32 "	57mm	93mm	10	R
C107-1016	1/4 "	63mm	101mm	10	R
C107-1018	9/32 "	69mm	109mm	10	R
C107-1020	5/16 "	75mm	117mm	10	R
C107-1022	11/32 "	81mm	125mm	10	R
C107-1024	3/8 "	87mm	133mm	10	R
C107-1026	13/32 "	87mm	133mm	5	R
C107-1028	7/16 "	94mm	142mm	5	R
C107-1032	1/2 "	101mm	151mm	5	R

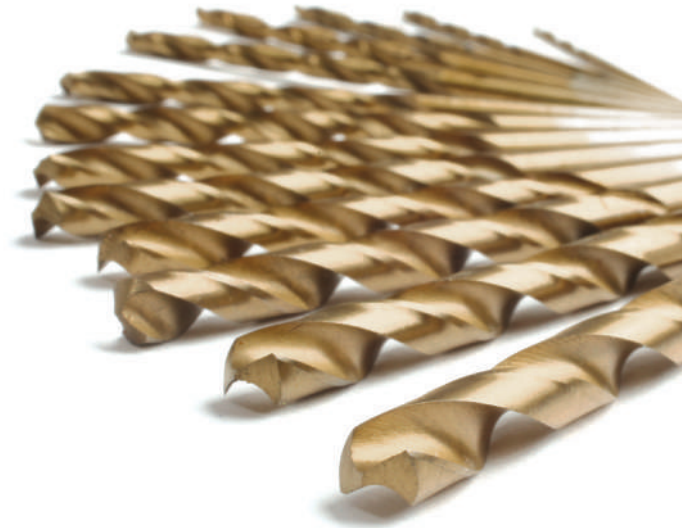

• LIST PRICE IS PER DRILL NOT PACK QTY

PACKAGING TYPE

## HSS-Co5 Cobalt Drill Sets



### HSS-Co5 Cobalt Drill Sets

Ground Flute			
CODE	DESCRIPTION & SIZE	PACK QTY	DISCOUNT GROUP
C109-0027	13Pcs.1.5 - 6.5mm x 0.5mm + 3.2, 4.8mm	1	R
5182-0019	19Pcs.1.0 - 10.0mm x 0.5mm	1	W
5182-0025	25Pcs.1.0 - 13.0mm x 0.5mm	1	W



See page 2 for cutting oil



STAINLESS  
STEEL



STEEL



CAST IRON



NON-FERROUS  
METAL



PLASTIC



# HSS-Co5 Cobalt Drills-Walleted

## SUITABLE FOR

Drilling alloyed and non-alloyed steel up to a tensile strength of 1000N/mm<sup>2</sup>, stainless steel V2A/V4A, cast steel, cast iron, acid and heat resistant steels.

## KEY FEATURES



135° Split point from 3mm or 1/8" and above. Self-centering split point drill tip means there is no need to pre-punch or pilot drill. This prevents wandering and enables faster penetration

### RECOMMENDED TAPPING & DRILL SIZES

TAP	DRILL
M3	- 2.50mm
M4	- 3.30mm
M5	- 4.20mm
M6	- 5.00mm
M8	- 6.80mm
M10	- 8.50mm
M12	- 10.20mm
M14	- 12.00mm

- ◆ **Manufactured to DIN 338**
- ◆ **M35 (5% cobalt)**
- ◆ **Ground flutes**
- ◆ **Straw finish**

CODE	DIAMETER	WORKING LENGTH	OVERALL LENGTH	PACK QTY	DISCOUNT GROUP
C107-0010W	1.0mm	12mm	34mm	1	R
C107-0015W	1.5mm	18mm	40mm	1	R
C107-0020W	2.0mm	24mm	49mm	1	R
C107-0025W	2.5mm	30mm	57mm	1	R
C107-0030W	3.0mm	33mm	61mm	1	R
C107-0032W	3.2mm	36mm	65mm	1	R
C107-0033W	3.3mm	36mm	65mm	1	R
C107-0035W	3.5mm	39mm	70mm	1	R
C107-0040W	4.0mm	43mm	75mm	1	R
C107-0042W	4.2mm	43mm	75mm	1	R
C107-0045W	4.5mm	47mm	80mm	1	R
C107-0048W	4.8mm	52mm	86mm	1	R
C107-0050W	5.0mm	52mm	86mm	1	R
C107-0055W	5.5mm	57mm	93mm	1	R
C107-0060W	6.0mm	57mm	93mm	1	R
C107-0065W	6.5mm	63mm	101mm	1	R
C107-0068W	6.8mm	63mm	101mm	1	R
C107-0070W	7.0mm	63mm	101mm	1	R
C107-0075W	7.5mm	69mm	109mm	1	R
C107-0080W	8.0mm	75mm	117mm	1	R
C107-0085W	8.5mm	75mm	117mm	1	R
C107-0090W	9.0mm	81mm	125mm	1	R
C107-0095W	9.5mm	81mm	125mm	1	R
C107-0100W	10.0mm	87mm	133mm	1	R
C107-0102W	10.2mm	87mm	133mm	1	R
C107-0105W	10.5mm	94mm	142mm	1	R
C107-0110W	11.0mm	94mm	142mm	1	R
C107-0115W	11.5mm	94mm	142mm	1	R
C107-0120W	12.0mm	101mm	151mm	1	R
C107-0125W	12.5mm	101mm	151mm	1	R
C107-0130W	13.0mm	101mm	151mm	1	R

Please contact us for more drill sizes  
+44 (0)114 261 7200  
info@castlebrooke.co.uk

# HSS-Co5 Cobalt Drills-Walleted



CODE	DIAMETER	WORKING LENGTH	OVERALL LENGTH	PACK QTY	DISCOUNT GROUP
C107-1004W	1/16 "	20mm	43mm	1	R
C107-1005W	5/64 "	24mm	49mm	1	R
C107-1006W	3/32 "	30mm	57mm	1	R
C107-1007W	7/64 "	33mm	61mm	1	R
C107-1008W	1/8 "	36mm	65mm	1	R
C107-1009W	9/64 "	39mm	70mm	1	R
C107-1010W	5/32 "	43mm	75mm	1	R
C107-1011W	11/64 "	47mm	80mm	1	R
C107-1012W	3/16 "	52mm	86mm	1	R
C107-1013W	13/64 "	52mm	86mm	1	R
C107-1014W	7/32 "	57mm	93mm	1	R
C107-1016W	1/4 "	63mm	101mm	1	R
C107-1018W	9/32 "	69mm	109mm	1	R
C107-1020W	5/16 "	75mm	117mm	1	R
C107-1022W	11/32 "	81mm	125mm	1	R
C107-1024W	3/8 "	87mm	133mm	1	R
C107-1026W	13/32 "	87mm	133mm	1	R
C107-1028W	7/16 "	94mm	142mm	1	R
C107-1032W	1/2 "	101mm	151mm	1	R

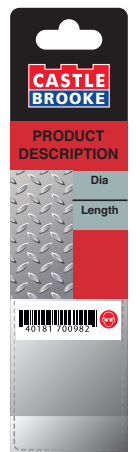
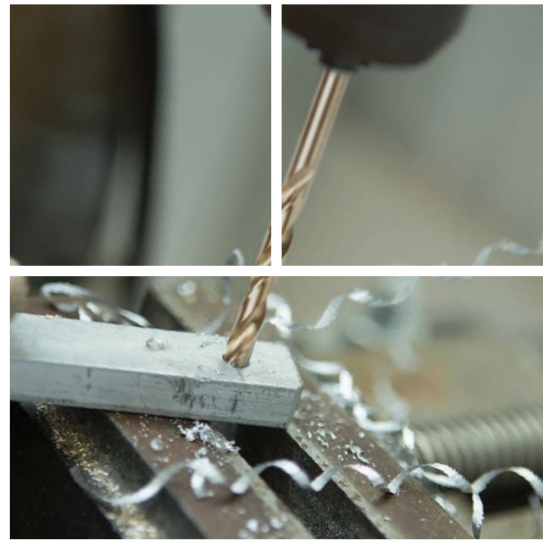

PACKAGING TYPE

See page 2 for cutting oil



STAINLESS STEEL



STEEL

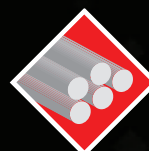

CAST IRON



NON-FERROUS METAL



PLASTIC



# HSS-Co5 Cobalt Long Series Drills



CODE	DIAMETER	WORKING LENGTH	OVERALL LENGTH	PACK QTY	DISCOUNT GROUP	CODE	DIAMETER	WORKING LENGTH	OVERALL LENGTH	PACK QTY	DISCOUNT GROUP
5117-0020	2.00mm	56mm	85mm	10	W	5117-0070	7.00mm	102mm	156mm	10	W
5117-0025	2.50mm	62mm	95mm	10	W	5117-0075	7.50mm	102mm	156mm	10	W
5117-0030	3.00mm	66mm	100mm	10	W	5117-0080	8.00mm	109mm	165mm	10	W
5117-0032	3.20mm	69mm	106mm	10	W	5117-0085	8.50mm	109mm	165mm	10	W
5117-0035	3.50mm	73mm	112mm	10	W	5117-0090	9.00mm	115mm	175mm	10	W
5117-0040	4.00mm	78mm	119mm	10	W	5117-0095	9.50mm	115mm	175mm	10	W
5117-0042	4.20mm	78mm	119mm	10	W	5117-0100	10.00mm	121mm	184mm	5	W
5117-0045	4.50mm	82mm	126mm	10	W	5117-0102	10.20mm	121mm	184mm	5	W
5117-0050	5.00mm	87mm	132mm	10	W	5117-0105	10.50mm	121mm	184mm	5	W
5117-0055	5.50mm	91mm	139mm	10	W	5117-0110	11.00mm	128mm	195mm	5	W
5117-0060	6.00mm	91mm	139mm	10	W	5117-0120	12.00mm	134mm	205mm	5	W
5117-0065	6.50mm	97mm	148mm	10	W	5117-0125	12.50mm	134mm	205mm	5	W
5117-0068	6.80mm	102mm	156mm	10	W	5117-0130	13.00mm	134mm	205mm	5	W

- ◆ **DIN 340**
- ◆ **M35 (5% Cobalt)**
- ◆ **135° split point**
- ◆ **Ground Flutes**
- ◆ **Bright finish**



# HSS-Co5 1/4" Hex Quick-Change Drill Bits (Impact Rated)



- ◆ **135° split point with 7 edge tips for superior drilling performance**

CODE	DIAMETER	WORKING LENGTH	OVERALL LENGTH	PACK QTY	DISCOUNT GROUP
C172-0025	2.50mm	19mm	62mm	1	R
C172-0030	3.00mm	23mm	65mm	1	R
C172-0033	3.30mm	24mm	67mm	1	R
C172-0035	3.50mm	25mm	69mm	1	R
C172-0040	4.00mm	26mm	71.5mm	1	R
C172-0042	4.20mm	28mm	74mm	1	R
C172-0045	4.50mm	29mm	76mm	1	R
C172-0050	5.00mm	31mm	80mm	1	R
C172-0055	5.50mm	60mm	104mm	1	R
C172-0060	6.00mm	63mm	105mm	1	R
C172-10SET	10Pc Set 2.5, 3.0, 3.3, 3.5, 4.0, 4.2, 4.5, 5.0, 5.5, 6.0mm			1	R

PACKAGING TYPE

C172-10SET  
PACKAGING TYPE

Please contact us for more drill sizes  
 +44 (0)114 261 7200  
 infocastlebrooke.co.uk



# HSS-Co5 Cobalt Blacksmith Drills



## SUITABLE FOR

Drilling alloyed and non-alloyed steel up to a tensile strength of 1000N/mm<sup>2</sup>, stainless steel V2A/V4A, cast steel, cast iron, acid and heat resistant steels.

## KEY FEATURES

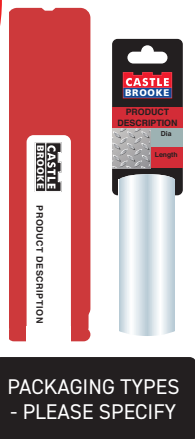
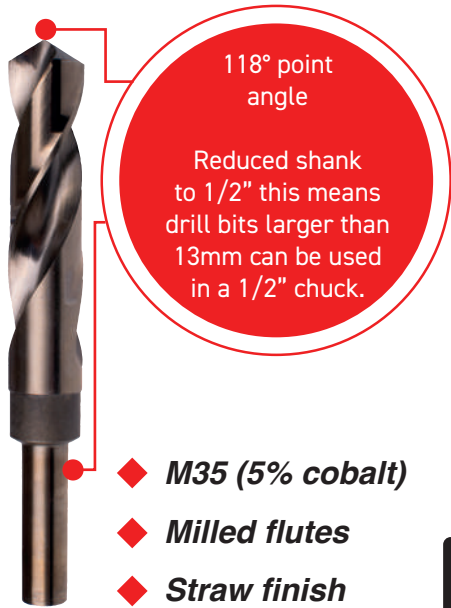

CODE	DIAMETER	WORKING LENGTH	OVERALL LENGTH	PACK QTY	DISCOUNT GROUP
5172-0135	13.5mm	80mm	152mm	1	W
5172-0140	14.0mm	80mm	152mm	1	W
5172-0145	14.5mm	80mm	152mm	1	W
5172-0150	15.0mm	80mm	152mm	1	W
5172-0155	15.5mm	80mm	152mm	1	W
5172-0160	16.0mm	80mm	152mm	1	W
5172-0165	16.5mm	80mm	152mm	1	W
5172-0170	17.0mm	80mm	152mm	1	W
5172-0175	17.5mm	80mm	152mm	1	W
5172-0180	18.0mm	80mm	152mm	1	W
5172-0185	18.5mm	80mm	152mm	1	W
5172-0190	19.0mm	80mm	152mm	1	W
5172-0195	19.5mm	76mm	152mm	1	W
5172-0200	20.0mm	76mm	152mm	1	W
5172-0210	21.0mm	76mm	152mm	1	W
5172-0220	22.0mm	76mm	152mm	1	W
5172-0230	23.0mm	76mm	152mm	1	W
5172-0240	24.0mm	76mm	152mm	1	W
5172-0250	25.0mm	76mm	152mm	1	W

## RECOMMENDED TAPPING & DRILL SIZES

	M16	M18	M20	M22	M24
TAP					
DRILL	14.00mm	15.50mm	17.50mm	19.50mm	21.00mm

# Multi-Purpose 1/4" Hex Quick-Change Drill Bits (Impact Rated)



CODE	DIAMETER	WORKING LENGTH	OVERALL LENGTH	PACK QTY	DISCOUNT GROUP
C212-055150	5.5mm	90mm	150mm	1	R
C212-060150	6.0mm	90mm	150mm	1	R
C212-070150	7.0mm	90mm	150mm	1	R
C212-080150	8.0mm	90mm	150mm	1	R
C212-100150	10.0mm	90mm	150mm	1	R
C212-005SET	5Pc Set 5.5, 6.0, 7.0, 8.0, 10.0x150mm			1	R

## SUITABLE FOR

For drilling holes in masonry, concrete, brick, multi-layer materials, tiles, wood, plastic, metal plates & aluminium.

## KEY FEATURES

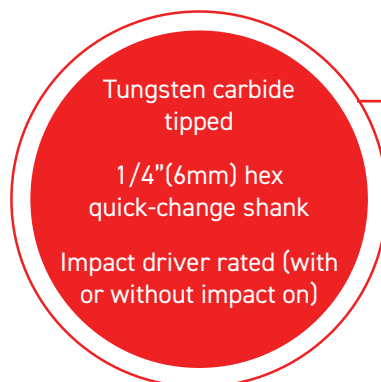

See page 2 for cutting oil

See page 56 for bit holders





# HSS Rotabor Cutters

## HSS ROTABOR CUTTERS SHORT SERIES 30mm WELDON 19mm (3/4") SHANK

CODE	DIAMETER	CUTTING DEPTH	PACK QTY	DISCOUNT GROUP
C241-423012	12.0mm	30.0mm	1	R
C241-423013	13.0mm	30.0mm	1	R
C241-423014	14.0mm	30.0mm	1	R
C241-423015	15.0mm	30.0mm	1	R
C241-423016	16.0mm	30.0mm	1	R
C241-423017	17.0mm	30.0mm	1	R
C241-423018	18.0mm	30.0mm	1	R
C241-423019	19.0mm	30.0mm	1	R
C241-423020	20.0mm	30.0mm	1	R
C241-423021	21.0mm	30.0mm	1	R
C241-423022	22.0mm	30.0mm	1	R
C241-423023	23.0mm	30.0mm	1	R
C241-423024	24.0mm	30.0mm	1	R
C241-423025	25.0mm	30.0mm	1	R
C241-423026	26.0mm	30.0mm	1	R
C241-423027	27.0mm	30.0mm	1	R
C241-423028	28.0mm	30.0mm	1	R
C241-423029	29.0mm	30.0mm	1	R
C241-423030	30.0mm	30.0mm	1	R
C241-423031	31.0mm	30.0mm	1	R
C241-423032	32.0mm	30.0mm	1	R
C241-423033	33.0mm	30.0mm	1	R
C241-423034	34.0mm	30.0mm	1	R
C241-423035	35.0mm	30.0mm	1	R

## HSS ROTABOR CUTTERS LONG SERIES 50mm WELDON 19mm (3/4") SHANK

CODE	DIAMETER	CUTTING DEPTH	PACK QTY	DISCOUNT GROUP
C241-425012	12.0mm	50.0mm	1	R
C241-425013	13.0mm	50.0mm	1	R
C241-425014	14.0mm	50.0mm	1	R
C241-425015	15.0mm	50.0mm	1	R
C241-425016	16.0mm	50.0mm	1	R
C241-425017	17.0mm	50.0mm	1	R
C241-425018	18.0mm	50.0mm	1	R
C241-425019	19.0mm	50.0mm	1	R
C241-425020	20.0mm	50.0mm	1	R
C241-425021	21.0mm	50.0mm	1	R
C241-425022	22.0mm	50.0mm	1	R
C241-425023	23.0mm	50.0mm	1	R
C241-425024	24.0mm	50.0mm	1	R
C241-425025	25.0mm	50.0mm	1	R
C241-425026	26.0mm	50.0mm	1	R
C241-425027	27.0mm	50.0mm	1	R
C241-425028	28.0mm	50.0mm	1	R
C241-425029	29.0mm	50.0mm	1	R
C241-425030	30.0mm	50.0mm	1	R
C241-425031	31.0mm	50.0mm	1	R
C241-425032	32.0mm	50.0mm	1	R
C241-425033	33.0mm	50.0mm	1	R
C241-425034	34.0mm	50.0mm	1	R
C241-425035	35.0mm	50.0mm	1	R

### SUITABLE FOR

Drilling of large holes in Alloyed and Non-Alloyed Steel, for example, beams, girders, constructional steel and steel plate.



### SHORT PILOT - FOR 30mm CUTTERS

CODE	DIAMETER	PACK QTY	DISCOUNT GROUP
C241-4230P	Short Straight Pilot	1	R

### LONG PILOT - FOR 50mm CUTTERS

CODE	DIAMETER	PACK QTY	DISCOUNT GROUP
C241-4250P	Long Straight Pilot	1	R



PACKAGING TYPES - PLEASE SPECIFY

For use in Magnetic Drilling Machines and Pillar Drills with MTS Adaptor

Please contact us for larger diameters and HSS-Co cutters.  
 +44 (0)114 261 7200  
 info@castlebrooke.co.uk

# HSS Centre, Step & Taper Drills



## HSS CENTRE DRILLS



**SUITABLE FOR**  
General centering operations on workpieces requiring additional machining between centres.

118° point angle with a 60° included countersink.

- ◆ **Manufactured to DIN 333A\***
- ◆ **Manufactured to BS 328\*\***



NON-FERROUS METAL



STEEL



PLASTIC

CODE	DIAMETER X BODY DIAMETER X OVERALL LENGTH	PACK QTY
C108-0010*	1.0 x 3.15 x 31.5mm	1
C108-0016*	1.6 x 4.0 x 35.5mm	1
C108-0020*	2.0 x 5.0 x 40mm	1
C108-0025*	2.5 x 6.3 x 45mm	1
C108-00315*	3.15 x 8.0 x 50mm	1
C108-0040*	4.0 x 10.0 x 55mm	1
C108-0050*	5.0 x 12.5 x 63mm	1
C108-0063*	6.3 x 16.0 x 71mm	1
C108-1001**	BS1 3/64 x 1/8 x 1.1/2"	1
C108-1002**	BS2 1/16 x 3/16 x 1.3/4"	1
C108-1003**	BS3 3/32 x 1/4 x 2"	1
C108-1004**	BS4 1/8 x 5/16 x 2.1/4"	1
C108-1005**	BS5 3/16 x 7/16 x 2.1/2"	1
C108-1006**	BS6 1/4 x 5/8 x 3"	1
C108-1007**	BS7 5/16 x 3/4 x 3.1/2"	1



## HSS STEP DRILLS

**SUITABLE FOR**  
Drilling, enlarging and deburring holes in thin sheet metal up to a thickness of 2mm, lubricant is recommended.

- ◆ **M2 High Speed Steel**
- ◆ **Manufactured to DIN 1412 C**

3 Flatted shank



CODE	DIAMETER RANGE - STEP INCREMENTS OF 2mm	PACK QTY	DISCOUNT GROUP
C131-0001	STD12 4 - 12mm	1	E
C131-0002	STD20 4 - 20mm	1	E
C131-0003	STD30 4 - 30mm	1	E
C131-0004SET	3 Pc Set - 4-12, 4-20,4-30mm	1	E



THIN SHEET METAL



## HSS TAPER DRILLS

**SUITABLE FOR**  
Drilling, enlarging and deburring holes in thin sheet metal up to a thickness of 2mm, lubricant is recommended.

- ◆ **M2 High Speed Steel**
- ◆ **Manufactured to DIN 1412 C**

CODE	DIAMETER RANGE	PACK QTY	DISCOUNT GROUP
C130-0001	TD14 3-14mm	1	E
C130-0002	TD20 6-20mm	1	E
C130-0005	TD630 6-30mm	1	E
C130-0003	TD30 16-30mm	1	E
C130-0004	TD40 26-40mm	1	E



THIN SHEET METAL

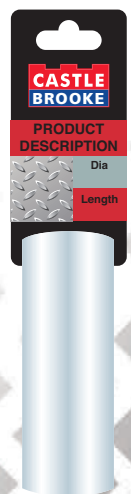

PACKAGING TYPES - PLEASE SPECIFY

See page 2 for cutting oil



## TCT Precision Drills



**SUITABLE FOR**  
Drilling hard steels and other difficult materials.

Carbide tipped cutting edge.

◆ **Manufactured to DIN 8037**



STEEL



NON-FERROUS METAL



STAINLESS STEEL

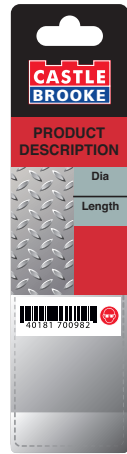

PACKAGING TYPE

CODE	DIAMETER x OVERALL LENGTH	PACK QTY	DISCOUNT GROUP
C140-0030	3.0 x 50mm	1	F
C140-0035	3.5 x 56mm	1	F
C140-0040	4.0 x 56mm	1	F
C140-0045	4.5 x 63mm	1	F
C140-0050	5.0 x 63mm	1	F
C140-0055	5.5 x 71mm	1	F
C140-0060	6.0 x 71mm	1	F
C140-0065	6.5 x 71mm	1	F
C140-0070	7.0 x 80mm	1	F
C140-0075	7.5 x 80mm	1	F
C140-0080	8.0 x 80mm	1	F
C140-0085	8.5 x 90mm	1	F
C140-0090	9.0 x 90mm	1	F
C140-0100	10.0 x 100mm	1	F
C140-0110	11.0 x 100mm	1	F
C140-0120	12.0 x 112mm	1	F
C140-0130	13.0 x 112mm	1	F
C140-1008	1/8 x 2"	1	F
C140-1012	3/16 x 2.1/2"	1	F
C140-1016	1/4 x 2.3/4"	1	F
C140-1020	5/16 x 3.1/8"	1	F
C140-1024	3/8 x 3.1/2"	1	F
C140-1028	7/16 x 4"	1	F
C140-1032	1/2 x 4.3/8"	1	F

## Tile & Glass Drills



**SUITABLE FOR**  
Drilling glass, ceramics and mirrors.

Carbide tipped cutting edge.

◆ **Nickel plated**



TILE

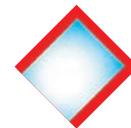

GLASS/MIRROR

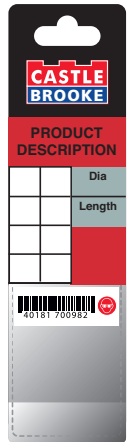

PACKAGING TYPE



CODE	DIAMETER x OVERALL LENGTH	PACK QTY	DISCOUNT GROUP
C280-0030	3.0 x 60mm	1	M
C280-0040	4.0 x 60mm	1	M
C280-0050	5.0 x 60mm	1	M
C280-0060	6.0 x 65mm	1	M
C280-0065	6.5 x 65mm	1	M
C280-0080	8.0 x 70mm	1	M
C280-0100	10.0 x 100mm	1	M
C280-0120	12.0 x 100mm	1	M
C280-199990SET	3.0, 4.0, 5.0, 6.0, 8.0, 10.0mm	1	M



**A set of the six most popular.**

# Vacuum Brazed Diamond Tile Core Drills



CODE	DIAMETER	WORKING LENGTH	OVERALL LENGTH	SUITABLE FOR	PACK QTY	DISCOUNT GROUP
C240-0070	6.0mm	27.0mm	60.0mm	Red Plugs	1	R
C240-0071	7.0mm	27.0mm	60.0mm	Brown Plugs	1	R
C240-0072	8.0mm	27.0mm	60.0mm	Blue Plugs	1	R
C240-0073	10.0mm	27.0mm	60.0mm	Grey Plugs / 8mm Pipe	1	R
C240-0074	12.0mm	27.0mm	60.0mm	Basin Set / 10mm Pipe	1	R
C240-0075	15.0mm	27.0mm	60.0mm	15mm Copper Pipe	1	R
C240-0076	20.0mm	27.0mm	60.0mm	19mm Copper Pipe Overflow Pipe	1	R
C240-0077	25.0mm	27.0mm	60.0mm	22mm Copper Pipe	1	R
C240-0078	30.0mm	27.0mm	60.0mm	28mm Copper Pipe	1	R
C240-0079	35.0mm	27.0mm	60.0mm	Waste Pipe	1	R

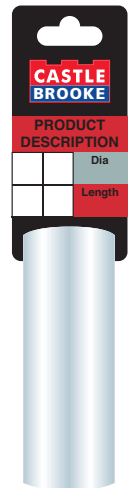

PACKAGING TYPE



## KEY FEATURES

1/4" quick-change shank.

Slug ejection hole.

Vacuum brazed diamond core surface.

## SUITABLE FOR

Porcelain (Grade 5), Granite, Marble, Ceramics, Terracotta, Glass, Quarry Tiles & Travertine.

Tile Core Drilling depth 27mm & Overall Length 60mm for all sizes listed above.



PORCELAIN

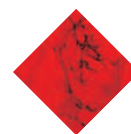

MARBLE



QUARRY TILE



GLASS

# Tile Drill Guide Water Dispenser



CODE	DIAMETER	PACK QTY	DISCOUNT GROUP
C240-0080	Tile drill guide water dispenser 5,6,7,8,10,12,15mm	1	R

- Suction pads for excellent grip on tiles
- Fill with water to allow the tile core drill to be cooled during drilling
- Holes sizes 5,6,7,8,10,12,15.

### For best results when drilling

1. Pre cool the tile core drill with a brief dip in coolant (water) or pour water around the area you wish to drill.
2. Offer up the tile core drill to the material at an angle of 45°
3. After creating a SMILE cut in the material raise the power tool to 90° and apply gentle pressure.
4. Gently oscillate the tile core drill in the hole, use a regular 5 second bursts during drilling.
5. Make sure the tile core drill is pre-dipped into the coolant (water) before every hole as per point 1. Tiles 10mm plus will need multiple dips.



PACKAGING TYPE



See page 56 for bit holders



# Masonry Drills

## SUITABLE FOR

Drilling holes in concrete, stone, and masonry.

For use in rotary Hammers.

Diameters 13mm and above will fit into a 13mm standard chuck.

## KEY FEATURES



Tungsten carbide tipped.

Reduced shank on diameters over 13mm for use with a 1/2" chuck.

◆ **Manufactured To Din 8035**

◆ **Nickel plated finish.**

CODE	DIAMETER	WORKING LENGTH	OVERALL LENGTH	PACK QTY	DISCOUNT GROUP
C210-030060	3.0mm	35mm	60mm	1	R
C210-040075	4.0mm	40mm	75mm	1	R
C210-045085	4.5mm	40mm	85mm	1	R
C210-050085	5.0mm	50mm	85mm	1	R
C210-050150	5.0mm	90mm	150mm	1	R
C210-055085	5.5mm	50mm	85mm	1	R
C210-055150	5.5mm	90mm	150mm	1	R
C210-060100	6.0mm	60mm	100mm	1	R
C210-060150	6.0mm	90mm	150mm	1	R
C210-060200	6.0mm	150mm	200mm	1	R
C210-060300	6.0mm	250mm	300mm	1	R
C210-060400	6.0mm	350mm	400mm	1	R
C210-065100	6.5mm	60mm	100mm	1	R
C210-065150	6.5mm	90mm	150mm	1	R
C210-065300	6.5mm	250mm	300mm	1	R
C210-065400	6.5mm	350mm	400mm	1	R
C210-070100	7.0mm	60mm	100mm	1	R
C210-070150	7.0mm	90mm	150mm	1	R
C210-070200	7.0mm	150mm	200mm	1	R
C210-070300	7.0mm	250mm	300mm	1	R
C210-070400	7.0mm	350mm	400mm	1	R
C210-080120	8.0mm	80mm	120mm	1	R
C210-080150	8.0mm	90mm	150mm	1	R
C210-080200	8.0mm	150mm	200mm	1	R
C210-080300	8.0mm	250mm	300mm	1	R
C210-080400	8.0mm	350mm	400mm	1	R
C210-080600	8.0mm	550mm	600mm	1	R
C210-081000	8.0mm	750mm	1000mm	1	R
C210-090120	9.0mm	80mm	120mm	1	R
C210-090150	9.0mm	90mm	150mm	1	R
C210-090300	9.0mm	250mm	300mm	1	R
C210-100120	10.0mm	80mm	120mm	1	R
C210-100150	10.0mm	90mm	150mm	1	R
C210-100200	10.0mm	150mm	200mm	1	R
C210-100300	10.0mm	250mm	300mm	1	R
C210-100400	10.0mm	350mm	400mm	1	R
C210-100600	10.0mm	550mm	600mm	1	R

Please contact us for more drill sizes  
+44 (0)114 261 7200  
info@castlebrooke.co.uk



BRICK



STONE



CONCRETE



CONCRETE  
BLOCK

# Masonry Drills



CODE	DIAMETER	WORKING LENGTH	OVERALL LENGTH	PACK QTY	DISCOUNT GROUP
C210-101000	10.0mm	740mm	1000mm	1	R
C210-110150	11.0mm	90mm	150mm	1	R
C210-110200	11.0mm	150mm	200mm	1	R
C210-110300	11.0mm	250mm	300mm	1	R
C210-110400	11.0mm	350mm	400mm	1	R
C210-120150	12.0mm	90mm	150mm	1	R
C210-120200	12.0mm	150mm	200mm	1	R
C210-120300	12.0mm	250mm	300mm	1	R
C210-120400	12.0mm	350mm	400mm	1	R
C210-120600	12.0mm	550mm	600mm	1	R
C210-121000	12.0mm	740mm	1000mm	1	R
C210-130150	13.0mm	90mm	150mm	1	R
C210-130200	13.0mm	150mm	200mm	1	R
C210-130300	13.0mm	250mm	300mm	1	R
C210-130400	13.0mm	350mm	400mm	1	R
C210-140150	14.0mm	90mm	150mm	1	R
C210-140200	14.0mm	150mm	200mm	1	R
C210-140300	14.0mm	250mm	300mm	1	R
C210-140400	14.0mm	350mm	400mm	1	R
C210-140600	14.0mm	550mm	600mm	1	R
C210-150200	15.0mm	150mm	200mm	1	R
C210-150300	15.0mm	250mm	300mm	1	R
C210-160150	16.0mm	90mm	150mm	1	R
C210-160200	16.0mm	150mm	200mm	1	R
C210-160300	16.0mm	250mm	300mm	1	R
C210-160400	16.0mm	350mm	400mm	1	R
C210-160600	16.0mm	550mm	600mm	1	R
C210-180160	18.0mm	90mm	160mm	1	R
C210-180200	18.0mm	150mm	200mm	1	R
C210-180300	18.0mm	250mm	300mm	1	R
C210-180400	18.0mm	350mm	400mm	1	R
C210-200160	20.0mm	90mm	160mm	1	R
C210-200220	20.0mm	150mm	220mm	1	R
C210-200300	20.0mm	250mm	300mm	1	R
C210-200400	20.0mm	350mm	400mm	1	R
C210-200600	20.0mm	550mm	600mm	1	R
C210-220160	22.0mm	90mm	160mm	1	R
C210-220220	22.0mm	150mm	220mm	1	R
C210-220300	22.0mm	250mm	300mm	1	R
C210-220400	22.0mm	350mm	400mm	1	R
C210-240220	24.0mm	150mm	220mm	1	R
C210-240400	24.0mm	350mm	400mm	1	R
C210-250160	25.0mm	90mm	160mm	1	R
C210-250220	25.0mm	150mm	220mm	1	R
C210-250300	25.0mm	250mm	300mm	1	R
C210-250400	25.0mm	350mm	400mm	1	R



PACKAGING TYPE



*A set of the five most popular sizes.*

CODE	DESCRIPTION	PACK QTY	DISCOUNT GROUP
C210-199997SET	5.0x85, 6.0x100, 7.0x100, 8.0x120, 10.0x120mm	1	R



# SDS Plus Hammer Drill Bits

## SUITABLE FOR

Drilling holes in concrete, stone, and masonry.

For use in rotary hammers with SDS Plus holding system.

## KEY FEATURES



C230-019998SET  
C230-019999SET  
C230-020000SET  
PACKAGING TYPE

CODE	DIAMETER	WORKING LENGTH	OVERALL LENGTH	PACK QTY	DISCOUNT GROUP
C230-040110	4.0mm	50mm	110mm	1	X
C230-040160	4.0mm	100mm	160mm	1	X
C230-050110	5.0mm	50mm	110mm	1	X
C230-050160	5.0mm	100mm	160mm	1	X
C230-050210	5.0mm	150mm	210mm	1	X
C230-055110	5.5mm	50mm	110mm	1	X
C230-055160	5.5mm	100mm	160mm	1	X
C230-055210	5.5mm	150mm	210mm	1	X
C230-055260	5.5mm	200mm	260mm	1	X
C230-060110	6.0mm	50mm	110mm	1	X
C230-060160	6.0mm	100mm	160mm	1	X
C230-060210	6.0mm	150mm	210mm	1	X
C230-060260	6.0mm	200mm	260mm	1	X
C230-065110	6.5mm	50mm	110mm	1	X
C230-065160	6.5mm	100mm	160mm	1	X
C230-065210	6.5mm	150mm	210mm	1	X
C230-065260	6.5mm	200mm	260mm	1	X
C230-070110	7.0mm	50mm	110mm	1	X
C230-070160	7.0mm	100mm	160mm	1	X
C230-070210	7.0mm	150mm	210mm	1	X
C230-080110	8.0mm	50mm	110mm	1	X
C230-080160	8.0mm	100mm	160mm	1	X
C230-080210	8.0mm	150mm	210mm	1	X
C230-080260	8.0mm	200mm	260mm	1	X
C230-080460	8.0mm	400mm	460mm	1	X
C230-090160	9.0mm	100mm	160mm	1	X
C230-090210	9.0mm	150mm	210mm	1	X
C230-100110	10.0mm	50mm	110mm	1	X
C230-100160	10.0mm	100mm	160mm	1	X
C230-100210	10.0mm	150mm	210mm	1	X
C230-100260	10.0mm	200mm	260mm	1	X
C230-100310	10.0mm	250mm	310mm	1	X
C230-100360	10.0mm	300mm	360mm	1	X
C230-100460	10.0mm	400mm	460mm	1	X
C230-100600	10.0mm	550mm	600mm	1	X
C230-101000	10.0mm	950mm	1000mm	1	X
C230-110160	11.0mm	100mm	160mm	1	X

CODE	DESCRIPTION	PACK QTY	DISCOUNT GROUP
C230-019998SET	5Pc Set, 5.5,6.0,6.5,7.0,8.0 x 210mm	1	X
C230-019999SET	6Pc Set, 5.5,6.0,6.5,7.0,8.0,10.0 x 160mm	1	X
C230-020000SET	5Pc Set, 5.5,6.0,7.0,8.0,10.0 x 160mm	1	X

+44 (0)114 261 7200  
info@castlebrooke.co.uk



# SDS Plus Hammer Drill Bits



CODE	DIAMETER	WORKING LENGTH	OVERALL LENGTH	PACK QTY	DISCOUNT GROUP
C230-110210	11.0mm	150mm	210mm	1	X
C230-110260	11.0mm	200mm	260mm	1	X
C230-120160	12.0mm	100mm	160mm	1	X
C230-120210	12.0mm	150mm	210mm	1	X
C230-120260	12.0mm	200mm	260mm	1	X
C230-120310	12.0mm	250mm	310mm	1	X
C230-120450	12.0mm	400mm	450mm	1	X
C230-120600	12.0mm	550mm	600mm	1	X
C230-121000	12.0mm	950mm	1000mm	1	X
C230-130160	13.0mm	100mm	160mm	1	X
C230-130210	13.0mm	150mm	210mm	1	X
C230-130300	13.0mm	250mm	310mm	1	X
C230-130450	13.0mm	400mm	450mm	1	X
C230-140160	14.0mm	100mm	160mm	1	X
C230-140210	14.0mm	150mm	210mm	1	X
C230-140260	14.0mm	200mm	260mm	1	X
C230-140310	14.0mm	250mm	310mm	1	X
C230-140450	14.0mm	400mm	450mm	1	X
C230-140600	14.0mm	550mm	600mm	1	X
C230-141000	14.0mm	950mm	1000mm	1	X
C230-150160	15.0mm	100mm	160mm	1	X
C230-150210	15.0mm	150mm	210mm	1	X
C230-150250	15.0mm	200mm	250mm	1	X
C230-150450	15.0mm	400mm	450mm	1	X
C230-160160	16.0mm	100mm	160mm	1	X
C230-160210	16.0mm	150mm	210mm	1	X
C230-160260	16.0mm	200mm	260mm	1	X
C230-160310	16.0mm	250mm	310mm	1	X
C230-160450	16.0mm	400mm	450mm	1	X
C230-160600	16.0mm	550mm	600mm	1	X
C230-160800	16.0mm	750mm	800mm	1	X
C230-161000	16.0mm	950mm	1000mm	1	X
C230-180200	18.0mm	150mm	200mm	1	X
C230-180250	18.0mm	200mm	250mm	1	X
C230-180300	18.0mm	250mm	300mm	1	X
C230-180450	18.0mm	400mm	450mm	1	X

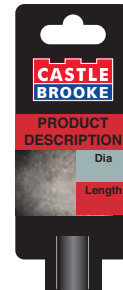
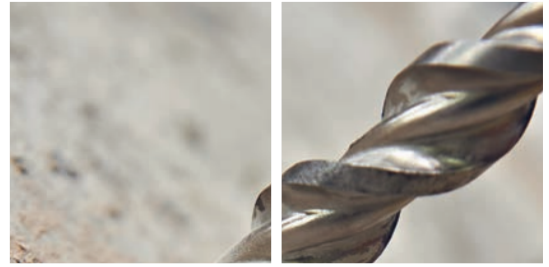

PACKAGING TYPE



PACKAGING TYPE



## Chisel/Chisel & Drill Bit Sets

CODE	DESCRIPTION	PACK QTY	DISCOUNT GROUP
C237-SDSPUSSET1	3Pcs SET - Point 250mm, Chisel 20x250mm, Wide Chisel 40x250mm	1	M
C230-020002SET	8Pcs SET - Point 250mm, Chisel 20x250mm, Wide chisel 40x250mm. Drill Bits 5.5, 6.0, 7.0x160mm, 8, 10x210mm	1	X



BRICK



STONE

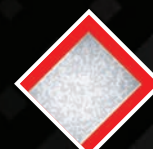

CONCRETE



CONCRETE  
BLOCK



# SDS Plus Hammer Drill Bits

## SUITABLE FOR

Drilling holes in concrete, stone, and masonry.

For use in rotary hammers with SDS Plus holding system.

## KEY FEATURES



- Tungsten Carbide tipped.
- Bright finish with anti-corrosion finish.
- 4 flute enables faster debris removal.



CODE	DIAMETER	WORKING LENGTH	OVERALL LENGTH	PACK QTY	DISCOUNT GROUP
C230-181000	18.0mm	950mm	1000mm	1	X
C230-190200	19.0mm	150mm	200mm	1	X
C230-190450	19.0mm	400mm	450mm	1	X
C230-200210	20.0mm	150mm	210mm	1	X
C230-200300	20.0mm	250mm	310mm	1	X
C230-200450	20.0mm	400mm	450mm	1	X
C230-200600	20.0mm	550mm	600mm	1	X
C230-201000	20.0mm	950mm	1000mm	1	X
C230-220250	22.0mm	200mm	250mm	1	X
C230-220310	22.0mm	250mm	310mm	1	X
C230-220450	22.0mm	400mm	450mm	1	X
C230-220600	22.0mm	550mm	600mm	1	X
C230-221000	22.0mm	950mm	1000mm	1	X
C230-240250	24.0mm	200mm	250mm	1	X
C230-240450	24.0mm	400mm	450mm	1	X
C230-250210	25.0mm	150mm	210mm	1	X
C230-250250	25.0mm	200mm	250mm	1	X
C230-250450	25.0mm	400mm	450mm	1	X
C230-250600	25.0mm	550mm	600mm	1	X
C230-251000	25.0mm	950mm	1000mm	1	X
C230-260250	26.0mm	200mm	250mm	1	X
C230-260450	26.0mm	400mm	450mm	1	X
C230-260600	26.0mm	550mm	600mm	1	X
C230-280450	28.0mm	400mm	450mm	1	X
C230-300450	30.0mm	400mm	450mm	1	X

+44 (0)114 261 7200  
info@castlebrooke.co.uk



BRICK



STONE

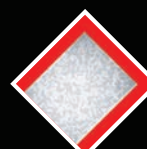

CONCRETE



CONCRETE BLOCK

# SDS Plus Quad Hammer Drill Bits



CODE	DIAMETER	WORKING LENGTH	OVERALL LENGTH	PACK QTY	DISCOUNT GROUP
C234-050110	5.0mm	50mm	110mm	1	X
C234-050160	5.0mm	100mm	160mm	1	X
C234-055160	5.5mm	100mm	160mm	1	X
C234-060110	6.0mm	50mm	110mm	1	X
C234-060160	6.0mm	100mm	160mm	1	X
C234-060210	6.0mm	150mm	210mm	1	X
C234-065210	6.5mm	150mm	210mm	1	X
C234-070160	7.0mm	100mm	160mm	1	X
C234-070210	7.0mm	150mm	210mm	1	X
C234-080160	8.0mm	100mm	160mm	1	X
C234-080210	8.0mm	150mm	210mm	1	X
C234-080260	8.0mm	200mm	260mm	1	X
C234-100160	10.0mm	100mm	160mm	1	X
C234-100210	10.0mm	150mm	210mm	1	X
C234-100260	10.0mm	200mm	260mm	1	X
C234-120160	12.0mm	100mm	160mm	1	X
C234-120210	12.0mm	150mm	210mm	1	X
C234-160460	16.0mm	400mm	460mm	1	X
C234-180460	18.0mm	400mm	460mm	1	X
C234-200460	20.0mm	400mm	460mm	1	X
C234-220460	22.0mm	400mm	460mm	1	X
C234-250460	25.0mm	400mm	460mm	1	X
C234-020002SET	8Pcs SET - Point 250mm, Chisel 20x250mm, Wide chisel 40x250mm, Drill Bits 5.5, 6.0, 7.0x160mm, 8, 10x210mm			1	X

## SUITABLE FOR

Drilling holes in concrete, stone, and masonry.

For use in rotary hammers with SDS Plus holding system.

## KEY FEATURES

- 4 tungsten carbide tips cutting edges for drilling clean accurate holes
- Bright finish with anti-corrosion finish
- 4 flute enables faster debris removal
- Long life

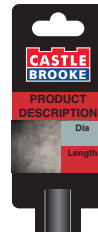

PACKAGING TYPE

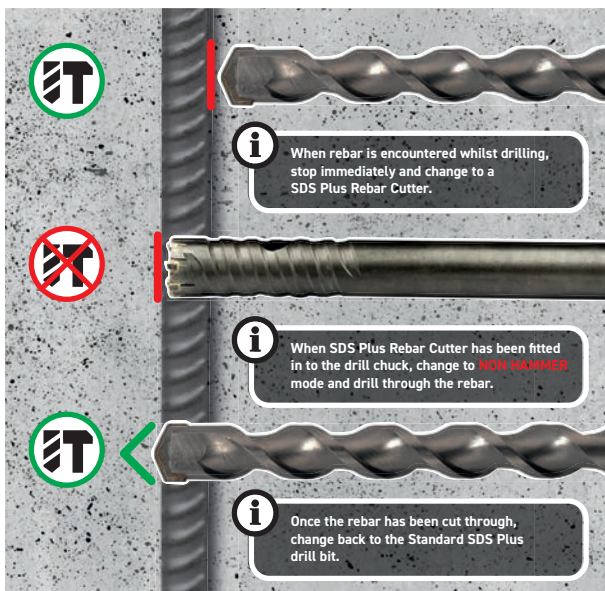

# SDS Plus Rebar Cutters

CODE	DIAMETER	WORKING LENGTH	OVERALL LENGTH	PACK QTY	DISCOUNT GROUP
C236-100300	10.0mm	80mm	300mm	1	X
C236-120300	12.0mm	80mm	300mm	1	X
C236-140300	14.0mm	80mm	300mm	1	X
C236-160300	16.0mm	80mm	300mm	1	X
C236-180300	18.0mm	80mm	300mm	1	X
C236-200300	20.0mm	80mm	300mm	1	X
C236-250300	25.0mm	80mm	300mm	1	X

## SUITABLE FOR

Drilling through rebar in concrete





# SDS Max Hammer Drill Bits

## SUITABLE FOR

Drilling large diameter holes in concrete, stone, and masonry. For use in rotary hammers with SDS Max holding system.

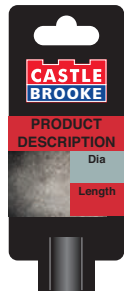

PACKAGING TYPE



## KEY FEATURES



4 tungsten carbide tips cutting edges for drilling clean accurate holes.

Bright finish with anti-corrosion finish.

4 flute enables faster debris removal.

Long life.



CODE	DIAMETER	WORKING LENGTH	OVERALL LENGTH	PACK QTY	DISCOUNT GROUP
C238-120340	12.0mm	200mm	340mm	1	L
C238-120540	12.0mm	400mm	540mm	1	L
C238-140340	14.0mm	200mm	340mm	1	L
C238-140540	14.0mm	400mm	540mm	1	L
C238-150340	15.0mm	200mm	340mm	1	L
C238-150540	15.0mm	400mm	540mm	1	L
C238-160340	16.0mm	200mm	340mm	1	L
C238-160540	16.0mm	400mm	540mm	1	L
C238-180340	18.0mm	200mm	340mm	1	L
C238-180540	18.0mm	400mm	540mm	1	L
C238-200370	20.0mm	220mm	370mm	1	L
C238-200520	20.0mm	400mm	520mm	1	L
C238-200920	20.0mm	800mm	920mm	1	L
C238-220370	22.0mm	220mm	370mm	1	L
C238-220520	22.0mm	400mm	520mm	1	L
C238-220920	22.0mm	800mm	920mm	1	L
C238-240370	24.0mm	220mm	370mm	1	L
C238-240520	24.0mm	400mm	520mm	1	L
C238-250320	25.0mm	200mm	320mm	1	L
C238-250370	25.0mm	220mm	370mm	1	L
C238-250520	25.0mm	400mm	520mm	1	L
C238-250920	25.0mm	800mm	920mm	1	L
C238-260520	26.0mm	400mm	520mm	1	L
C238-280370	28.0mm	220mm	370mm	1	L
C238-280570	28.0mm	440mm	570mm	1	L
C238-280920	28.0mm	800mm	920mm	1	L
C238-300370	30.0mm	220mm	370mm	1	L
C238-300570	30.0mm	440mm	570mm	1	L
C238-300920	30.0mm	800mm	920mm	1	L
C238-320370	32.0mm	220mm	370mm	1	L
C238-320570	32.0mm	440mm	570mm	1	L
C238-320920	32.0mm	800mm	920mm	1	L
C238-350370	35.0mm	220mm	370mm	1	L
C238-350570	35.0mm	440mm	570mm	1	L
C238-350920	35.0mm	800mm	920mm	1	L
C238-380570	38.0mm	440mm	570mm	1	L
C238-400570	40.0mm	440mm	570mm	1	L
C238-500570	50.0mm	440mm	570mm	1	L
C238-500920	50.0mm	800mm	920mm	1	L

CODE	DESCRIPTION	PACK QTY	DISCOUNT GROUP
C800-0629	SDS MAX TO SDS PLUS QUICK FIT ADAPTOR 225mm o/a	1	L



STONE



CONCRETE



CONCRETE BLOCK



BRICK

# Heavy Duty TCT Core Drills & Adaptors



## KEY FEATURES

- Fast cut carbide tip geometry
- Drilling depth of 75mm for all sizes
- Overall length 100mm
- Debris transporting body Flutes

## KEY CODE COMBINATIONS

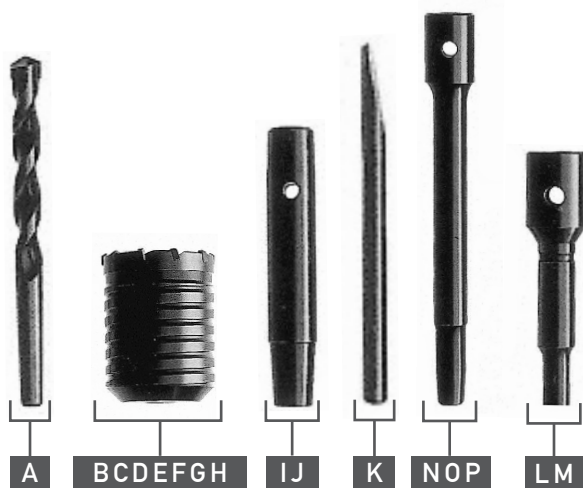

Code	DIAMETER, LENGTH & DESCRIPTION	KEY CODE	PACK QTY	DISCOUNT GROUP
<b>Core Shell Only</b>				
C240-0034	50mm	B	1	F
C240-0036	65mm	C	1	F
C240-0037	76mm	D	1	F
C240-0041	100mm	E	1	F
C240-0042	115mm	F	1	F
C240-0043	125mm	G	1	F
C240-0044	150mm	H	1	F
<b>Core Shell Complete Unit Comprising: Core Shell, 120mm Adaptor, Pilot Drill And Drift Key.</b>				
C240-0019	50mm	A,B,I,K	1	F
C240-0021	65mm	A,C,I,K	1	F
C240-0022	76mm	A,D,I,K	1	F
C240-0026	100mm	A,E,I,K	1	F
C240-0027	115mm	A,F,I,K	1	F
C240-0028	125mm	A,G,I,K	1	F
C240-0029	150mm	A,H,I,K	1	F
<b>Pilot Drill</b>				
C245-0001	11 x 225mm 'A' Taper	A	1	F
<b>Drift Key</b>				
C245-0002	Drift Key	K	1	F
<b>Adaptor Shank for Core Shells</b>				
C240-0058	120mm	I	1	F
C240-0059	250mm	J	1	F
<b>K Taper Extension Rods</b>				
C240-0061	250mm	N	1	F
C240-0062	400mm	O	1	F
C240-0063	550mm	P	1	F
<b>Hammer Drill Adaptors To K Taper</b>				
C800-0446	SDS Plus 110mm	L	1	J
C800-0066	SDS Max 180mm	M	1	J

## HEAVY DUTY TCT CORE DRILLS.

It is attention to every detail that makes the Heavy Duty core Drills class leaders. They are machined from solid steel billets. Both interior and exterior surfaces are machined to standards eliminating any fear of future fatigue failures.

The tungsten carbide tips are designed for fast cutting. The "chipbreaker" tip seat reliefs ensure that debris is transported

away from the workplace quickly. The body flutes move the debris out of the cut.

There are more carbide tips in a Heavy Duty Core Drill. This extends life and provides the user with exceptional value for money.

More carbide tips mean a smoother operation. Accuracy of top seating and precision body machining ensures snag free cutting which is kinder to the operator and the machine.

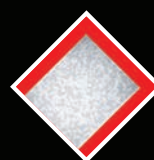

CONCRETE



STONE



CONCRETE  
BLOCK



BRICK

# HAMMER BREAKER STEELS ELECTRIC, PNEUMATIC & HYDRAULIC



CHASING  
GOUGE



POINT



CLAYSPADE



CRANKED  
WIDE CHISEL



MORTAR  
RAKE  
CHISEL



WIDE  
CHISEL



COMB  
HOLDER



TIE TAMPER



FLOOR  
CLEANING  
TOOL



ASPHALT  
CUTTER



PAD



NARROW  
CHISEL



TARMAC  
CUTTER



STEM



POST  
DRIVER/  
EARTH ROD  
DRIVER



BUSH  
HAMMER  
HEAD TOOL

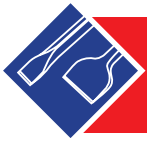

# SDS Plus Hammer Breaker Steels - Electric



CODE	DESCRIPTION	BLADE WIDTH	OVERALL LENGTH	PACK QTY	DISCOUNT GROUP
C237-00001	Point		250mm (10")	1	M
C237-00002	Narrow Chisel	20mm	250mm (10")	1	M
C237-00003	Wide Chisel Straight	40mm	250mm (10")	1	M
C237-00009	Wide Chisel - Cranked	40mm	250mm (10")	1	M
C237-00005	Wide Chisel - Straight	75mm (3")	160mm (6")	1	M
C237-00006	Wide Chisel - Cranked	75mm (3")	160mm (6")	1	M
C237-SDSPLUSSET1	3Pc Set-Point & Chisel x 250mm (10") Wide Chisel 40x250mm (10")			1	M
C237-00004	Chasing Gouge	22mm (7/8")	250mm (10")	1	M
C237-00007	*Scutch Comb Holder	38mm (1.1/2")	200mm (8")	1	M
C237-00008	Mortar Rake Chisel - Carbide Tipped	70x20x7mm	185mm (7")	1	M
C237-00010	Floor/Wall Scraper Tool	100mm (4")	250mm (10")	1	M
C237-00011	Spare Blade + Nuts & Bolts For C237-00010	100mm (4")		1	M
C237-00016	Bush Hammer head Tool TCT 16 point pad, 35mm square		145mm (5.3/4")	1	M
C237-00017	Earth Rod Driver	20mm (7/8") i/d	170mm (6.3/4")	1	M

**SUITABLE FOR** Breaking and removal of concrete, concrete block, stone, and brick. For use in rotary stop hammer with SDS Plus holding system.

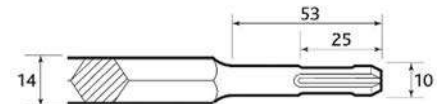

# SDS Max Hammer Breaker Steels - Electric

**SUITABLE FOR** breaking and removal of concrete, concrete block, stone and brick. For use in rotary stop hammer with SDS Max holding system.

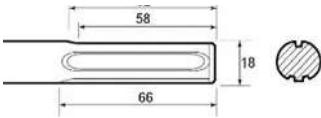
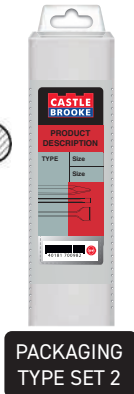

CODE	DESCRIPTION	BLADE WIDTH	OVERALL LENGTH	PACK QTY	DISCOUNT GROUP
C255-914900	Point		300mm (12")	1	Q
C255-914903	Point		400mm (16")	1	Q
C255-914904	Point		450mm (18")	1	Q
C255-914905	Point		600mm (24")	1	Q
C255-914907	Point		900mm (36")	1	Q
C255-914909	Point		1200mm (47")	1	Q
C255-914910	Narrow Chisel	25mm (1")	300mm (12")	1	Q
C255-914913	Narrow Chisel	25mm (1")	400mm (16")	1	Q
C255-914914	Narrow Chisel	25mm (1")	450mm (18")	1	Q
C255-914915	Narrow Chisel	25mm (1")	600mm (24")	1	Q
C255-914917	Narrow Chisel	25mm (1")	900mm (36")	1	Q
C255-914919	Chisel	25mm (1")	1200mm (47")	1	Q
C255-914924	Wide Chisel	50mm (2")	300mm (12")	1	Q
C255-914925	Wide Chisel	50mm (2")	400mm (16")	1	Q
C255-914935	Wide Chisel	75mm (3")	300mm (12")	1	Q
C255-914936	Wide Chisel - Cranked	75mm (3")	300mm (12")	1	Q
C255-914945	Wide Chisel	115mm (4.1/2")	350mm (14")	1	Q
C255-914941	*Scutch Comb Holder	38mm (1.1/2")	300mm (12")	1	Q
C255-SDSMAXSET1	3Pc Set-Point & Chisel x 400mm(16") Wide Chisel 80x300mm (3"x12")			1	Q
C255-SDSMAXSET2	3Pc Set-Point & Chisel x 300mm(12") Wide Chisel 50x300mm (2"x12")			1	Q
C255-914980	Chasing Gouge	25mm (2")	300mm (12")	1	Q
C255-914985	Clayspade	100 x 165mm (4"x6.1/2")	450mm (18")	1	Q
C255-914986	Asphalt Cutter	90mm (3.1/2")	450mm (18")	1	Q
C255-914961	Earth Rod Driver	20mm (7/8") i/d	250mm (10")	1	Q
C255-914991	Bush Hammer Head Tool - TCT 25 Point Pad 40mm Square		280mm (11")	1	Q
C255-914977	Stem to suit floor scraping tool & pads. See page 31		400mm (16")	1	Q

SEE PAGE 31 FOR ACCESSORIES

\*Comb not included, see page 31

+44 (0)114 261 7200  
info@castlebrooke.co.uk



## Kango 900/950K Hammer Breaker Steels - Electric

### SUITABLE FOR

Breaking and removal of concrete, concrete block, stone, and brick.

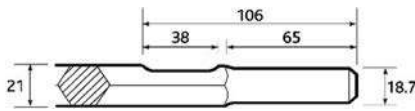

CODE	DESCRIPTION	BLADE WIDTH	OVERALL LENGTH	PACK QTY	DISCOUNT GROUP
C255-914112	Point		380mm (15")	1	Q
C255-914113	Point		450mm (18")	1	Q
C255-914213	Point		600mm (24")	1	Q
C255-914118	Narrow Chisel	25mm (1")	380mm (15")	1	Q
C255-914119	Narrow Chisel	25mm (1")	450mm (18")	1	Q
C255-914219	Narrow Chisel	25mm (1")	600mm (24")	1	Q
C255-914474	*Scutch Comb holder	38mm (1.1/2")	300mm (12")	1	Q
C255-914475	Wide Chisel	50mm (2")	300mm (12")	1	Q
C255-914476	Wide Chisel	75mm (3")	300mm (12")	1	Q
C255-914481	Clayspade	100 x 165mm (4"x6.1/2")	450mm (18")	1	Q
C255-914483	Stem to suit floor scraping tool & pads. See page 31		275mm (11")	1	Q



## Bosch 11304/GSH27, Hammer Breaker Steels - Electric

### SUITABLE FOR

Breaking and removal of concrete, concrete block, stone, and brick.

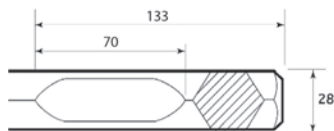

CODE	DESCRIPTION	BLADE WIDTH	OVERALL LENGTH	PACK QTY	DISCOUNT GROUP
C255-914610	Point		380mm (15")	1	Q
C255-914611	Point		450mm (18")	1	Q
C255-914620	Narrow Chisel	28mm (1.1/8")	380mm (15")	1	Q
C255-914621	Narrow Chisel	28mm (1.1/8")	450mm (18")	1	Q
C255-914642	Wide Chisel	75 x 50mm (3"x2")	400mm (16")	1	Q
C255-914650	Tarmac Cutter	115 x 125mm (4.1/2"x5")	380mm (15")	1	Q
C255-914660	Clayspade	125 x 205mm (5"x8")	500mm (20")	1	Q
C255-BOSCHSET1	3Pc Set-Point & Chisel x 450mm (18") Wide Chisel 75x400mm (3"x18")			1	Q
C255-914690	Stem to suit pads		380mm (15")	1	Q
C255-912904	Pad 125mm dia to suit stem C255-914690	125mm dia. (5")		1	Q
C255-912906	Pad 180mm dia to suit stem C255-914690	180mm dia (7")		1	Q
C251-912916	Pad 150mm SQ to suit stem C255-914690	150x150mm (6")		1	Q

\*Comb not included, see page 31



+44 (0)114 261 7200  
info@castlebrooke.co.uk

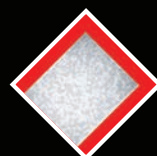

CONCRETE



STONE



CONCRETE  
BLOCK



BRICK



## Hilti TE3000 Hammer Breaker Steels - Electric



### SUITABLE FOR

Breaking and removal of concrete, concrete block, stone, and brick.

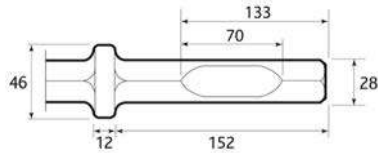

CODE	DESCRIPTION	BLADE WIDTH	OVERALL LENGTH	PACK QTY	DISCOUNT GROUP
C255-934612	Point		500mm (20")	1	Q
C255-934622	Narrow Chisel	28mm (1.1/8")	500mm (20")	1	Q
C255-934642	Wide Chisel	75mm (3")	500mm (20")	1	Q
C255-934647	Asphalt Cutter	125x150mm (5"x6")	500mm (18")	1	Q

## Hilti TE3000 Quick-Change Hammer Breaker Steels - Electric



### SUITABLE FOR

Breaking and removal of concrete, concrete block, stone, and brick.

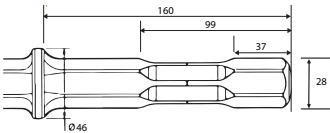

CODE	DESCRIPTION	BLADE WIDTH	OVERALL LENGTH	PACK QTY	DISCOUNT GROUP
C255-944612	Point		500mm (20")	1	Q
C255-944622	Narrow Chisel	28mm (1.1/8")	500mm (20")	1	Q

## Hilti TE905, TE1000 & TE2000 Hammer Breaker Steels - Electric



### SUITABLE FOR

Breaking and removal of concrete, concrete block, stone, and brick.

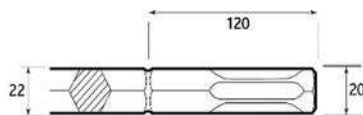

CODE	DESCRIPTION	BLADE WIDTH	OVERALL LENGTH	PACK QTY	DISCOUNT GROUP
C255-914972	Point		360mm (14")	1	Q
C255-914974	Point		500mm (20")	1	Q
C255-914979	Point		900mm (36")	1	Q
C255-914982	Narrow Chisel	28mm (1.1/8")	360mm (14")	1	Q
C255-914984	Narrow Chisel	28mm (1.1/8")	500mm (20")	1	Q
C255-914989	Narrow Chisel	28mm (1.1/8")	900mm (36")	1	Q
C255-914995	Wide Chisel	75mm (3")	360mm (14")	1	Q
C255-914996	Wide Chisel	75mm (3")	500mm (20")	1	Q
C255-914993	Clayspade	100 x 165mm (4"x6.1/2")	450mm (18")	1	Q
C255-HILTISET1	3Pc Set-Point & Chisel x 500mm(20") Wide Chisel	75x500mm (3"x20")		1	Q
C255-100514	Stem to suit floor scraping tool & pads. See page 31		300mm (12")	1	Q

## Makita 8035NB/HM0810 Hammer Breaker Steels - Electric



### SUITABLE FOR

Breaking and removal of concrete, concrete block, stone, and brick.

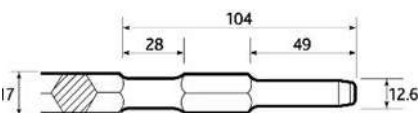

CODE	DESCRIPTION	BLADE WIDTH	OVERALL LENGTH	PACK QTY	DISCOUNT GROUP
C255-914783	Point		280mm (11")	1	Q
C255-914784	Point		450mm (18")	1	Q
C255-914793	Narrow Chisel	22mm (7/8")	280mm (11")	1	Q
C255-914794	Narrow Chisel	22mm (7/8")	450mm (18")	1	Q
C255-914803	Wide Chisel	50mm (2")	280mm (11")	1	Q
C255-914804	Wide Chisel	75mm (3")	300mm (12")	1	Q



# Hitachi PH65A & Makita HM1317C Hammer Breaker Steels - Electric

## SUITABLE FOR

Breaking and removal of concrete, concrete block, stone, and brick.

CODE	DESCRIPTION	BLADE WIDTH	OVERALL LENGTH	PACK QTY	DISCOUNT GROUP
C255-914614	Point		410mm (16")	1	Q
C255-914624	Narrow Chisel	25mm (1")	410mm (16")	1	Q
C255-914632	Wide Chisel	75 x 50mm (3"x2")	410mm (16")	1	Q

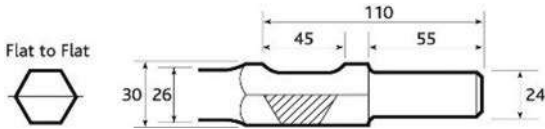

## Accessories

## SUITABLE FOR

Floor cleaning tool suitable for removing tiles and laminates from the flooring.

Scutch Comb for dressing stone.

CODE	DESCRIPTION	PACK QTY	DISCOUNT GROUP
C255-100134	Floor Scraping Tool to suit Stems - SDS Max, Hilti, Kango 2.0 x 150mm (6") wide	1	Q
C255-100156	Spare Blade for C255-100134 2.0 x 150mm (6") wide	1	Q
C255-100134RK	Repair Kit including Nuts, Bolts, Washers & Gaskets for C255-00134	1	Q
C255-100563	Pad 100mm dia to suit Stems - SDS Max, Kango, Hilti	1	Q
C255-100521	Pad 150 x 125mm to suit Stems - SDS Max, Kango, Hilti	1	Q
C255-914485	Scutch Comb 38mm (1.1/2") wide	1	Q

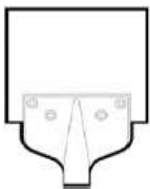

C255-100134

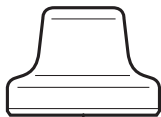

C255-100563

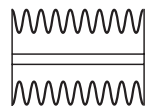

C255-914485

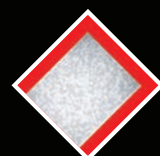

CONCRETE



STONE



CONCRETE BLOCK



BRICK

# Hexagon Shank 19x50mm (3/4" x 2") Breaker Steels - Pneumatic & Hydraulic



## SUITABLE FOR

Breaking and removal of concrete, concrete block, stone, and brick.

CODE	DESCRIPTION	BLADE WIDTH	UNDER COLLAR	PACK QTY	DISCOUNT GROUP
C251-912011	Point		250mm (10")	1	Q
C251-912014	Point		450mm (18")	1	Q
C251-912211	Narrow Chisel	19mm (3/4")	250mm (10")	1	Q
C251-912214	Narrow Chisel	19mm (3/4")	450mm (18")	1	Q
C251-912121	Wide Chisel	50mm (2")	250mm (10")	1	Q
C251-912151	Wide Chisel	75mm (3")	250mm (10")	1	Q

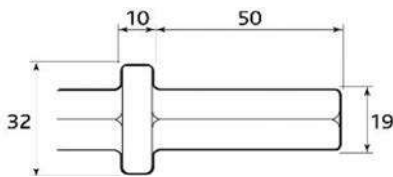

◆ **Long steels available please contact us for more details.**

# Hexagon Shank 22x82mm (7/8" x 3.1/4") Breaker Steels - Pneumatic & Hydraulic



## SUITABLE FOR

Breaking and removal of concrete, concrete block, stone and brick.

CODE	DESCRIPTION	BLADE WIDTH	UNDER COLLAR	PACK QTY	DISCOUNT GROUP
C251-910023	Point		380mm (15")	1	Q
C251-910024	Point		450mm (18")	1	Q
C251-910233	Narrow Chisel	22mm (7/8")	380mm (15")	1	Q
C251-910234	Narrow Chisel	22mm (7/8")	450mm (18")	1	Q
C251-910420	Wide Chisel	75 x 50mm (3"x2")	380mm (15")	1	Q
C251-910913	Clayspade	100 x 165mm (4"x6.1/2")	380mm (15")	1	Q
C251-910910	Stem To Suit Pad (small bore)		205mm (8")	1	Q
C251-912905	Pad (small bore)	125mm dia (5")		1	Q

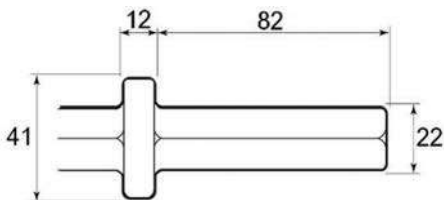

◆ **Long steels available please contact us for more details.**

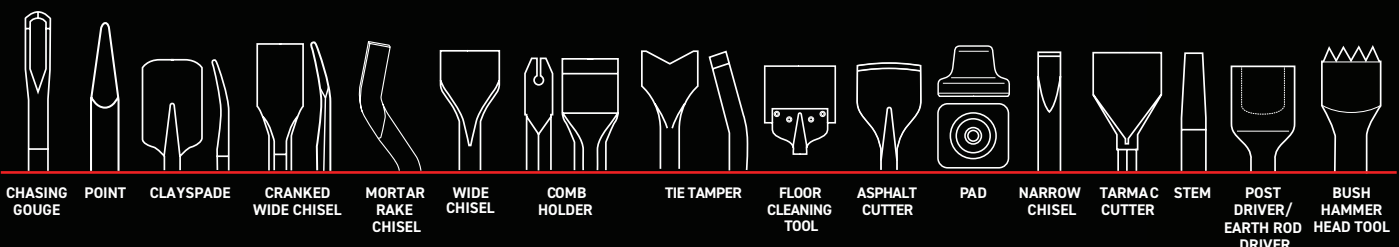

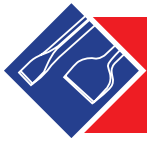

## Hexagon Shank 25x108mm (1" x 4.1/4") Breaker Steels - Pneumatic & Hydraulic

### SUITABLE FOR

Breaking and removal of concrete, concrete block, stone, and brick.

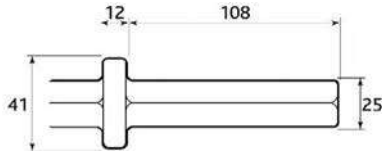

CODE	DESCRIPTION	BLADE WIDTH	UNDER COLLAR	PACK QTY	DISCOUNT GROUP
C251-910043	Point		380mm (15")	1	Q
C251-910044	Point		450mm (18")	1	Q
C251-910253	Narrow Chisel	25mm (1")	380mm (15")	1	Q
C251-910254	Narrow Chisel	25mm	450mm (18")	1	Q
C251-910430	Wide Chisel	75 x 50mm (3"x2")	380mm (3")	1	Q
C251-910435	Tarmac Cutter	115 x 125mm (4.1/2"x5")	305mm (12")	1	Q
C251-910911	Stem to suit pad (small bore)		205mm (8")	1	Q
C251-912905	Pad (small bore)	125mm dia. (5")		1	Q



## Hexagon Shank 28x160mm (1.1/8" x 6.1/4") Breaker Steels - Pneumatic & Hydraulic

### SUITABLE FOR

Breaking and removal of concrete, concrete block, stone, and brick.

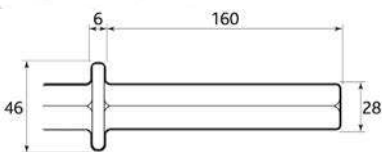

CODE	DESCRIPTION	BLADE WIDTH	UNDER COLLAR	PACK QTY	DISCOUNT GROUP
C251-912063	Point		380mm (15")	1	Q
C251-912064	Point		450mm (18")	1	Q
C251-912273	Narrow Chisel	28mm (1.1/8")	380mm (15")	1	Q
C251-912274	Narrow Chisel	28mm (1.1/8")	450mm (18")	1	Q
C251-912440	Wide Chisel	75 x 50mm (3"x2")	380mm (15")	1	Q
C251-912545	Tarmac Cutter	115 x 125mm (4.1/2"x5")	280mm (11")	1	Q
C251-912901	Stem to suit pads (large bore)		230mm (9")	1	Q
C255-912904	Pad (large bore)	125mm dia. (5")		1	Q
C255-912906	Pad (large bore)	180mm dia. (7")		1	Q
C251-912916	Pad (large bore)	150 x 150mm (6")		1	Q
C251-200565	Post Driver	62mm Dia (2.1/2") i/d	155mm (6")	1	Q

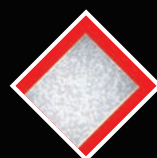

CONCRETE



STONE



CONCRETE BLOCK



BRICK

# Hexagon Shank 32x160mm (1.1/4" x 6.1/4") Breaker Steels - Pneumatic & Hydraulic



## SUITABLE FOR

Breaking and removal of concrete, concrete block, stone, and brick.

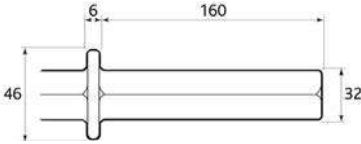

◆ **Long steels available please contact us for more details.**

CODE	DESCRIPTION	BLADE WIDTH	UNDER COLLAR	PACK QTY	DISCOUNT GROUP
C251-912081	Point		300mm (12")	1	Q
C251-912083	Point		380mm (15")	1	Q
C251-912084	Point		450mm (18")	1	Q
C251-912291	Narrow Chisel	32mm (1.1/4")	300mm (12")	1	Q
C251-912293	Narrow Chisel	32mm (1.1/4")	380mm (15")	1	Q
C251-912294	Narrow Chisel	32mm (1.1/4")	450mm (18")	1	Q
C251-912450	Wide Chisel	75 x 50mm (3"x2")	380mm (15")	1	Q
C251-912454	Asphalt Cutter (curved edge)	125 x 150mm (5"x6")	330mm (13")	1	Q
C251-912555	Tarmac Cutter	115 x 125mm (4.1/2"x5")	300mm (12")	1	Q
C251-912668	Clayspade	140 x 230mm (5.1/2"x9")	380mm (15")	1	Q
C251-912903	Stems To Suit Pads (large bore)		230mm (9")	1	Q
C255-912904	Pad (large bore)	125mm dia (5")		1	Q
C255-912906	Pad (large bore)	180mm dia (7")		1	Q
C251-912916	Pad (large bore)	150 x 150mm (6")		1	Q
C251-912351	Tie Tamper	100x50mm (4"x2")	450mm (18")	1	Q
C251-200570	Post Driver	62mm Dia (2.1/2") i/d	155mm (6")	1	Q

# Picking Hammers Breaker Steels - Pneumatic & Hydraulic

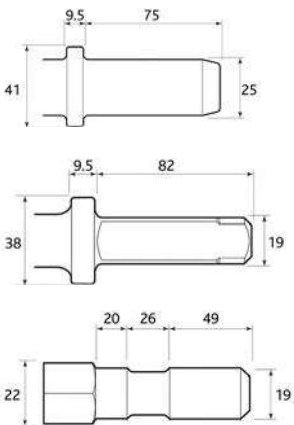

CODE	DESCRIPTION	BLADE WIDTH	UNDER COLLAR	PACK QTY	DISCOUNT GROUP
<b>Picking Hammer SK12</b>					
C251-914025	Point		330mm (12")	1	Q
C251-914225	Narrow Chisel	25mm (1")	330mm (12")	1	Q
<b>Picking Hammer FL22</b>					
C251-914009	Point		330mm (12")	1	Q
C251-914029	Narrow Chisel	25mm (1")	330mm (12")	1	Q
C251-914609	Clayspade	100 x 165mm (4"x6.1/2")	380mm (15")	1	Q
<b>CP9</b>					
<b>OVERALL LENGTH</b>					
C251-914049	Point		250mm (10")	1	Q
C251-914249	Narrow Chisel	25mm (1")	250mm (10")	1	Q
C251-914449	Wide Chisel	75mm (3")	250mm (10")	1	Q

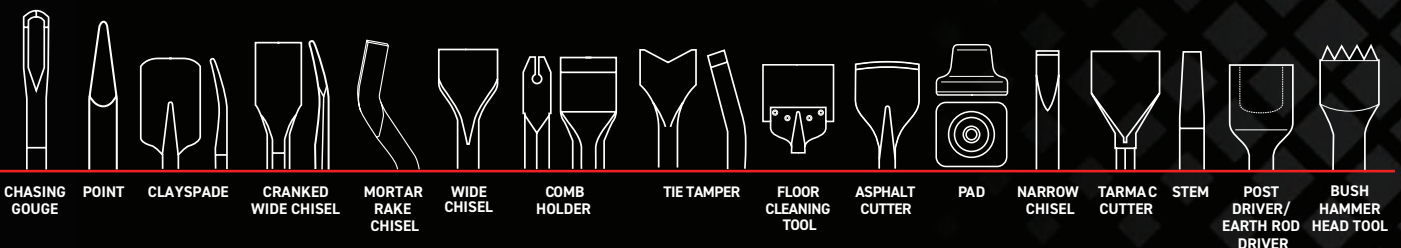



# Wood Auger Bits

## SUITABLE FOR

Drilling large diameter holes into thick hardwood and softwood.

## KEY FEATURES



**Screw Point**  
 6mm hexagon shank for 6-8mm  
 8mm hexagon shank for 10-14mm  
 11mm hexagon shank for 16-38mm.

◆ **Black and bright finish**



PACKAGING TYPES  
PLEASE SPECIFY



CODE	CODE SDS+ SHANK	DIAMETER	WORKING LENGTH	OVERALL LENGTH	PACK QTY	DISCOUNT GROUP
C310-060230		6.0mm	160mm	230mm	1	M
C310-060460		6.0mm	360mm	460mm	1	M
C310-080230		8.0mm	160mm	230mm	1	M
C310-080460		8.0mm	360mm	460mm	1	M
C310-100230		10.0mm	160mm	230mm	1	M
C310-100460		10.0mm	360mm	460mm	1	M
C310-120230		12.0mm	160mm	230mm	1	M
C310-120460		12.0mm	360mm	460mm	1	M
C310-130230		13.0mm	260mm	230mm	1	M
C310-140230		14.0mm	160mm	230mm	1	M
C310-140460		14.0mm	360mm	460mm	1	M
C310-160100		16.0mm	60mm	100mm	1	M
C310-160230	C311-160205	16.0mm	160mm	230mm	1	M
C310-160460		16.0mm	360mm	460mm	1	M
C310-180230	C311-180205	18.0mm	160mm	230mm	1	M
C310-180460		18.0mm	360mm	460mm	1	M
C310-190230		19.0mm	160mm	230mm	1	M
C310-200100		20.0mm	60mm	100mm	1	M
C310-200230	C311-200205	20.0mm	160mm	230mm	1	M
C310-200460		20.0mm	360mm	460mm	1	M
C310-220230	C311-220205	22.0mm	160mm	230mm	1	M
C310-220460		22.0mm	360mm	460mm	1	M
C310-240230		24.0mm	160mm	230mm	1	M
C310-240460		24.0mm	360mm	460mm	1	M
C310-250100		25.0mm	60mm	100mm	1	M
C310-250230	C311-250205	25.0mm	160mm	230mm	1	M
C310-250460		25.0mm	360mm	460mm	1	M
C310-260230		26.0mm	160mm	230mm	1	M
C310-260460		26.0mm	360mm	460mm	1	M
C310-280230	C311-280205	28.0mm	160mm	230mm	1	M
C310-280460		28.0mm	360mm	460mm	1	M
C310-300230	C311-300205	30.0mm	160mm	230mm	1	M
C310-300460		30.0mm	360mm	460mm	1	M
C310-320100		32.0mm	60mm	100mm	1	M
C310-320230	C311-320205	32.0mm	160mm	230mm	1	M
C310-320460		32.0mm	360mm	460mm	1	M
C310-350230		35.0mm	160mm	230mm	1	M
C310-380230		38.0mm	160mm	230mm	1	M
C310-199998SET		10,12,14,16,18,20mm x 460mm			1	M
C310-199999SET		10,12,14,16,18,20mm x 230mm			1	M
C310-300EB		300mm(1/2") Extension Bar for 22.0mm and above, to fit a 13mm(1/2") chuck			1	M

Please contact us for more drill sizes  
 +44 (0)114 261 7200  
 info@castlebrooke.co.uk



HARDWOOD



SOFTWOOD

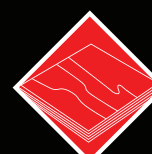

PLYWOOD



MDF

# Flat Wood Bits



CODE	DIAMETER	OVERALL LENGTH	PACK QTY	DISCOUNT GROUP
C330-0060	6.0mm	152mm	1	S
C330-0080	8.0mm	152mm	1	S
C330-0100	10.0mm	152mm	1	S
C330-0110	11.0mm	152mm	1	S
C330-0120	12.0mm	152mm	1	S
C330-0130	13.0mm	152mm	1	S
C330-0140	14.0mm	152mm	1	S
C330-0160	16.0mm	152mm	1	S
C330-0180	18.0mm	152mm	1	S
C330-0190	19.0mm	152mm	1	S
C330-0200	20.0mm	152mm	1	S
C330-0220	22.0mm	152mm	1	S
C330-0240	24.0mm	152mm	1	S
C330-0250	25.0mm	152mm	1	S
C330-0260	26.0mm	152mm	1	S
C330-0280	28.0mm	152mm	1	S
C330-0300	30.0mm	152mm	1	S
C330-0320	32.0mm	152mm	1	S
C330-0350	35.0mm	152mm	1	S
C330-0380	38.0mm	152mm	1	S

## SUITABLE FOR

Drilling large diameter holes into softwood and plywood.

## KEY FEATURES

Triple point design for a fast clean hole.

1/4" Quick-Change shank.



### ◆ 1/4" hexagon shank for use in 3 jaw chucks, 10mm(3/8") & 13mm(1/2")

CODE	LENGTH O/L DIAMETER	PACK QTY	DISCOUNT GROUP
<b>EXTENSION RODS</b>			
C335-0001	150mm Hex.	1	S
C335-0002	300mm Hex.	1	S
<b>6PCS FLAT WOOD BIT SET</b>			
C330-1998SET	10, 13, 16, 19, 22, 25mm	1	S

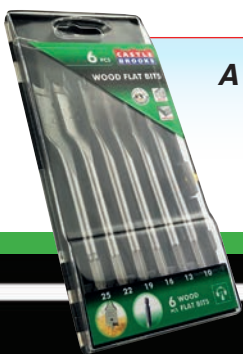

*A set of the six most popular.*



See page 56 for bit holders



SOFTWOOD

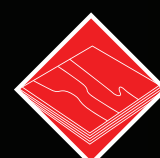

PLYWOOD



MDF



# Centre Spur Wood Drill Bits



## SUITABLE FOR

Drilling holes into softwood and plywood.

## KEY FEATURES

Centre spur point

Reduced shank on diameters over 13mm.

For use with 10mm(3/8") & 13mm(1/2") chucks.



PACKAGING TYPE



CODE	DIAMETER	WORKING LENGTH	OVERALL LENGTH	PACK QTY	DISCOUNT GROUP
C340-0030	3.0mm	30mm	60mm	1	M
C340-0040	4.0mm	40mm	70mm	1	M
C340-0050	5.0mm	45mm	85mm	1	M
C340-0060	6.0mm	50mm	90mm	1	M
C340-0070	7.0mm	60mm	105mm	1	M
C340-0080	8.0mm	65mm	110mm	1	M
C340-0090	9.0mm	70mm	115mm	1	M
C340-0100	10.0mm	75mm	120mm	1	M
C340-0110	11.0mm	80mm	142mm	1	M
C340-0120	12.0mm	95mm	150mm	1	M
C340-0130	13.0mm	95mm	150mm	1	M
C340-0140	14.0mm	95mm	150mm	1	M
C340-0160	16.0mm	105mm	160mm	1	M
C340-0200	20.0mm	140mm	200mm	1	M
<b>5 PCS CENTRE SPUR WOOD DRILL SET</b>					
C340-2000SET	4.0, 5.0, 6.0, 8.0, 10.0mm			1	M

*A set of the five most popular.*



# Forstner Bits



## SUITABLE FOR

Drilling blind holes into MDF, hardwood, softwood and plywood to accept cantilever door hinges.

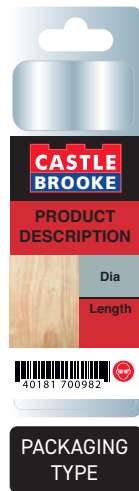

PACKAGING TYPE

CODE	DIAMETER	OVERALL LENGTH	PACK QTY	DISCOUNT GROUP
C330-90003	15.0mm	90mm	1	H
C330-90004	16.0mm	90mm	1	H
C330-90005	18.0mm	90mm	1	H
C330-90006	20.0mm	90mm	1	H
C330-90007	22.0mm	90mm	1	H
C330-90008	25.0mm	90mm	1	H
C330-90009	26.0mm	90mm	1	H
C330-90010	28.0mm	90mm	1	H
CODE	DIAMETER	OVERALL LENGTH	PACK QTY	DISCOUNT GROUP
C330-90011	30mm	90mm	1	H
C330-90012	35mm	90mm	1	H
C330-90013	40mm	90mm	1	H
C330-90014	45mm	90mm	1	H
C330-90015	50mm	90mm	1	H
<b>FORSTNER BIT SETS</b>				
C330-90016	15, 20, 25, 30, 35mm (5pc)		1	H
C330-90017	10, 12, 15, 16, 18, 20, 22, 25, 26, 28, 30, 35, 40, 45, 50mm (15pc)		1	H

+44 (0)114 261 7200  
info@castlebrooke.co.uk



# Triple Fluted Wood Drill Bits



## SUITABLE FOR

Drilling holes into thick hardwood and softwood.

CODE	DIAMETER	WORKING LENGTH	OVERALL LENGTH	PACK QTY	DISCOUNT GROUP
C350-0160	16.0mm	55mm	165mm	1	M
C350-0200	20.0mm	55mm	165mm	1	M
C350-0220	22.0mm	55mm	165mm	1	M
C350-0250	25.0mm	55mm	165mm	1	M
C350-0320	32.0mm	55mm	165mm	1	M

## KEY FEATURES

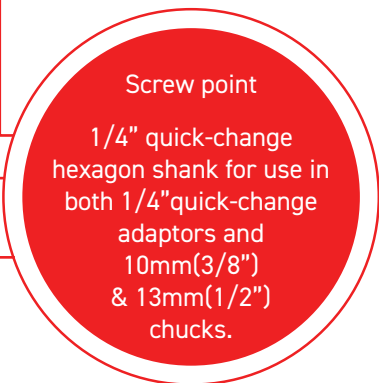

Screw point

1/4" quick-change hexagon shank for use in both 1/4" quick-change adaptors and 10mm(3/8") & 13mm(1/2") chucks.



PACKAGING TYPE



# TCT Router Bit

CODE	DIAMETER	BLADE LENGTH	SHANK	PACK QTY	DISCOUNT GROUP
C331-12750	12.7mm	50mm	1/2"	1	H



## SUITABLE FOR

Cutting MDF, chipboard, hardwood, plywood, softwood and laminates

# 1/4" (6mm) Hex Quick-Change Countersink Drill Bits



CODE	DIA	SCREW GAUGE No. SOFTWOOD	SCREW GAUGE No. HARDWOOD	PACK QTY	DISCOUNT GROUP
C332-0420	2.0mm	-	4	1	H
C332-0625	2.5mm	6	-	1	H
C332-0828	2.8mm	8	6	1	H
C332-1032	3.2mm	10	8	1	H
C332-1235	3.5mm	12	10	1	H
C332-5SET	5PCE Set 2.0, 2.5, 2.8, 3.2, 3.5mm		4-12	1	H

See page 56 for bit holders



HARDWOOD



SOFTWOOD

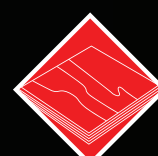

PLYWOOD



MDF



# Multi Tool Blades & Accessories

CODE	WIDTH x CUTTING DEPTH & DESCRIPTION	TPI	MATERIAL TO CUT	APPLICATION	PACK QTY	DISCOUNT GROUP
<b>BLADES - HIGH CARBON STEEL (HCS)</b>						
C400-03442	34x42mm Saw Blade	18	Wood	Cutting in softwood, plastic, plasterboard	1	M
C400-06442	64x42mm Saw Blade	18	Wood	Cutting in softwood, plastic, plasterboard	1	M
<b>BLADES - BI-METAL (BIM)</b>						
C401-03451	34x51mm Saw Blade	18	Wood/Metal	Plunge cutting in metal, softwood, hardwood, plastic, copper, plasterboard	1	M
C401-04451	44x51mm Saw Blade	18	Wood/Metal	Plunge cutting in metal, softwood, hardwood, plastic, copper, plasterboard	1	M
C401-08800	88x18mm Segment Saw Blade	18	Wood/Metal	Plunge cutting in metal, softwood, hardwood, plastic, copper, plasterboard	1	M
<b>BLADES - DIAMOND GRIT CUTTING EDGE</b>						
C402-03042	30x42mm Blade	-	Tile/Grout	Routing joints on wall & floor tiles, small cutouts in soft wall tiles, removing mortar, grout, tile adhesive	1	M
C402-08800	88x18mm Segment Blade	-	Tile/Grout	Routing joints on wall & floor tiles, small cutouts in soft wall tiles, removing mortar, grout, tile adhesive	1	M
<b>BLADES - STAINLESS STEEL SCRAPER BLADE</b>						
C404-05200	52mm Scraper Blade	-	-	Removing soft carpet, paint residues and silicon joints, adhesive residues	1	M

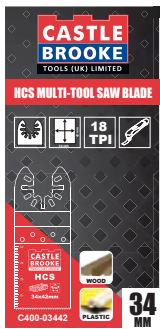

PACKAGING TYPE



C400-03442



PACKAGING TYPE



C401-08800



CODE	SIZE	GRIT	APPPLCIATION	PACK QTY	DISCOUNT GROUP
<b>SANDING - SANDING SHEETS - WITH HOOK &amp; LOOP FIXING</b>					
C403-0040G	80mm	40 (Coarse)	Wood	10	M
C403-0060G	80mm	60 (Medium)	Wood	10	M
C403-0080G	80mm	80 (Medium)	Wood	10	M
C403-0120G	80mm	120 (Fine)	Wood	10	M
C403-0240G	80mm	240 (Extra fine)	Wood	10	M
<b>SANDING - SANDING PLATE - WITH HOOK &amp; LOOP BACKING</b>					
C403-08000	80mm	-	-	1	M

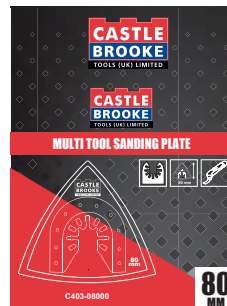

PACKAGING TYPE



C403-SANDING SHEETS



C403-08000

+44 (0)114 261 7200  
info@castlebrooke.co.uk



WOOD



NAIL-EMBEDDED WOOD



PLASTIC



STEEL



NON-FERROUS METAL

# HSS-Co8 Bi-Metal Sheet Steel Holesaws (8% Cobalt)



CODE	DIAMETER	WORKING DEPTH	BODY DEPTH	OVERALL LENGTH	PACK QTY	DISCOUNT GROUP
C417-0140	14.0mm 9/16"	1.6mm	12mm	65mm	1	M
C417-0160	16.0mm 5/8"	1.6mm	12mm	65mm	1	M
C417-0180	18.0mm 45/64"	1.6mm	12mm	65mm	1	M
C417-0200	20.0mm 25/32"	1.6mm	12mm	65mm	1	M
C417-0220	22.0mm 7/8"	1.6mm	12mm	65mm	1	M
C417-0250	25.0mm 1"	1.6mm	12mm	65mm	1	M
C417-0300	30.0mm 1.3/16"	1.6mm	12mm	65mm	1	M
C417-0320	32.0mm 1.1/4"	1.6mm	12mm	65mm	1	M
C417-0350	35.0mm 1.3/8"	1.6mm	12mm	65mm	1	M
C417-0380	38.0mm 1.1/2"	1.6mm	12mm	65mm	1	M
C417-0400	40.0mm 1.9/16"	1.6mm	12mm	65mm	1	M
<b>3 PCS KIT</b>						
C417-9001	3Pcs Set 1 x 20/25/32mm, Drive Arbor & pilot, Spring, Allen Key				1	M

## SUITABLE FOR

Mild steel, stainless steel & aluminium sheets up to 1.6mm in thickness

## KEY FEATURES

8% Cobalt Bi-metal cutting edge

8 TPI

Thin wall 0.6mm thick

1/4" quick-change shank

Impact driver rated

Stop shoulder to prevent over drilling

Ejector spring quickly ejects waste material



PACKAGING TYPE



C417-9011



C417-9010

CODE	DESCRIPTION & SIZE	PACK QTY	DISCOUNT GROUP
<b>ACCESSORIES</b>			
C417-9010	Drive Arbor & Pilot drill 4x12x65mm Sheet Steel Holesaw	1	M
C417-9011	Replacement Spring for Sheet Steel Holesaw	1	M
C610-0103	2.00mm Short Arm Hex Key	1	J



STAINLESS STEEL



WOOD



NAIL-EMBEDDED WOOD



PLASTIC



STEEL



NON-FERROUS METAL



# HSS Bi-Metal Holesaws

CODE	DIAMETER	CUTTING DEPTH	PACK QTY	DISCOUNT GROUP
C410-0140	14.0mm 9/16"	38mm	1	M
C410-0160	16.0mm 5/8"	39mm	1	M
C410-0170	17.0mm 11/16"	38mm	1	M
C410-0190	19.0mm 3/4"	38mm	1	M
C410-0200	20.0mm 25/32"	38mm	1	M
C410-0210	21.0mm 13/16"	38mm	1	M
C410-0220	22.0mm 7/8"	38mm	1	M
C410-0240	24.0mm 15/16"	38mm	1	M
C410-0250	25.0mm 1"	38mm	1	M
C410-0270	27.0mm 1.1/16"	38mm	1	M
C410-0290	29.0mm 1.1/8"	38mm	1	M
C410-0300	30.0mm 1.3/16"	38mm	1	M
C410-0320	32.0mm 1.1/4"	38mm	1	M
C410-0330	33.0mm 1.5/16"	38mm	1	M
C410-0350	35.0mm 1.3/8"	38mm	1	M
C410-0370	37.0mm 1.7/16"	38mm	1	M
C410-0380	38.0mm 1.1/2"	38mm	1	M
C410-0400	40.0mm 1.9/16"	38mm	1	M
C410-0410	41.0mm 1.5/8"	38mm	1	M
C410-0430	43.0mm 1.11/16"	38mm	1	M
C410-0440	44.0mm 1.3/4"	38mm	1	M
C410-0460	46.0mm 1.13/16"	38mm	1	M
C410-0480	48.0mm 1.7/8"	38mm	1	M
C410-0510	51.0mm 2"	38mm	1	M
C410-0520	52.0mm 2.1/16"	38mm	1	M
C410-0540	54.0mm 2.1/8"	38mm	1	M
C410-0550	55mm 2.3/16"	38mm	1	M
C410-0570	57.0mm 2.1/4"	38mm	1	M
C410-0590	59.0mm 2.5/16"	38mm	1	M
C410-0600	60.0mm 2.3/8"	38mm	1	M
C410-0640	64.0mm 2.1/2"	38mm	1	M
C410-0650	65.0mm 2.9/16"	38mm	1	M
C410-0670	67.0mm 2.5/8"	38mm	1	M
C410-0700	70.0mm 2.3/4"	38mm	1	M
C410-0730	73.0mm 2.7/8"	38mm	1	M
C410-0750	75.0mm 2.15/16"	38mm	1	M

CODE	DIAMETER	CUTTING DEPTH	PACK QTY	DISCOUNT GROUP
C410-0760	76.0mm 3"	38mm	1	M
C410-0790	79.0mm 3.1/8"	38mm	1	M
C410-0830	83.0mm 3.1/4"	38mm	1	M
C410-0860	86.0mm 3.3/8"	38mm	1	M
C410-0890	89.0mm 3.1/2"	38mm	1	M
C410-0920	92.0mm 3.5/8"	38mm	1	M
C410-0950	95.0mm 3.3/4"	38mm	1	M
C410-0980	98.0mm 3.7/8"	38mm	1	M
C410-1020	102.0mm 4"	38mm	1	M
C410-1050	105.0mm 4.1/8"	38mm	1	M
C410-1080	108.0mm 4.1/4"	38mm	1	M
C410-1110	111.0mm 4.3/8"	38mm	1	M
C410-1140	114.0mm 4.1/2"	38mm	1	M
C410-1210	121.0mm 4.3/4"	38mm	1	M
C410-1270	127.0mm 5"	38mm	1	M
C410-1400	140.0mm 5.1/2"	38mm	1	M
C410-1460	146.0mm 5.3/4"	38mm	1	M
C410-1520	152.0mm 6"	38mm	1	M
<b>LARGE DIAMETER BI-METAL HOLESAWS - A2C ARBOR TO SUITE</b>				
C415-1680	168.0mm 6.5/8"	38mm	1	G
C415-1770	177.0mm 7"	38mm	1	G
C415-1900	190.0mm 7.1/2"	38mm	1	G
C415-2000	200.0mm 7.5/8"	38mm	1	G
C415-2100	210.0mm 8.1/4"	38mm	1	G

## KEY FEATURES

Variable pitch tooth pattern which will clear dust more effectively and gives superior cutting performance.

**SUITABLE FOR** wood, plastic, steel and non-ferrous metals.

- ◆ **M3 HSS Bi-Metal Cutting Edge**
- ◆ **4/6 TPI**



**NOTE:** Holesaws do not include an arbor or pilot drill.

+44 (0)114 261 7200  
info@castlebrooke.co.uk



NAIL-EMBEDDED  
WOOD



WOOD



PLASTIC



STEEL



NON-FERROUS  
METAL

# HSS-Co8 Bi-Metal Holesaws (8% Cobalt)



CODE	DIAMETER	CUTTING DEPTH	PACK QTY	DISCOUNT GROUP
C411-0140	14.0mm 9/16"	38mm	1	M
C411-0160	16.0mm 5/8"	38mm	1	M
C411-0200	20.0mm 25/32"	38mm	1	M
C411-0220	22.0mm 7/8"	38mm	1	M
C411-0250	25.0mm 1"	38mm	1	M
C411-0270	27.0mm 1.1/16"	38mm	1	M
C411-0300	30.0mm 1.3/16"	38mm	1	M
C411-0320	32.0mm 1.1/4"	38mm	1	M
C411-0350	35.0mm 1.3/8"	38mm	1	M
C411-0380	38.0mm 1.1/2"	38mm	1	M
C411-0400	40.0mm 1.9/16"	38mm	1	M
C411-0440	44.0mm 1.3/4"	38mm	1	M
C411-0460	46.0mm 1.13/16"	38mm	1	M
C411-0510	51.0mm 2"	38mm	1	M
C411-0570	57.0mm 2.1/4"	38mm	1	M
C411-0600	60.0mm 2.3/8"	38mm	1	M
C411-0640	64.0mm 2.1/2"	38mm	1	M
C411-0670	67.0mm 2.5/8"	38mm	1	M
C411-0700	70.0mm 2.3/4"	38mm	1	M
C411-0730	73.0mm 2.7/8"	38mm	1	M
C411-0760	76.0mm 3"	38mm	1	M
C411-0790	79.0mm 3.1/8"	38mm	1	M
C411-0830	83.0mm 3.1/4"	38mm	1	M
C411-0860	86.0mm 3.1/4"	38mm	1	M
C411-0890	89.0mm 3.3/8"	38mm	1	M
C411-0950	95.0mm 3.3/4"	38mm	1	M
C411-1020	102.0mm 4"	38mm	1	M
C411-1110	111.0mm 4.3/8"	38mm	1	M
C411-1140	114.0mm 4.1/2"	38mm	1	M
C411-1270	127.0mm 5"	38mm	1	M
C411-1520	152.0mm 6"	38mm	1	M

## KEY FEATURES

Variable pitch tooth pattern which will clear dust more effectively and gives superior cutting performance.

**SUITABLE FOR** wood, nail, embedded wood, plastic, steel, stainless steel and non-ferrous metals.

◆ **M42 (8% Cobalt) HSS Bi-Metal Cutting Edge**

◆ **4/6 TPI**

**NOTE:** Holesaws do not include an arbor or pilot drill.

## Tungsten Carbide Tipped Holesaws

CODE	DIAMETER	CUTTING DEPTH	OVERALL LENGTH	PACK QTY	DISCOUNT GROUP
<b>TUNGSTEN CARBIDE TIPPED HOLESAWS</b>					
C418-014025	14.0mm 9/16"	25mm	80mm	1	M *
C418-016025	16.0mm 5/8"	25mm	80mm	1	M
C418-019025	19.0mm 3/4"	25mm	80mm	1	M
C418-020025	20.0mm 25/32"	25mm	80mm	1	M
C418-025025	25.0mm 1"	25mm	80mm	1	M
C418-032025	32.0mm 1.1/4"	25mm	80mm	1	M
C418-035025	35.0mm 1.3/8"	25mm	80mm	1	M
C418-038025	38.0mm 1.1/2"	25mm	80mm	1	M
C418-040025	38.0mm 1.1/2"	25mm	80mm	1	M
C418-045025	45.0mm 1.25/32"	25mm	80mm	1	M
C418-051025	51.0mm 2"	25mm	80mm	1	M
C418-064025	64.0mm 2.1/2"	25mm	80mm	1	M
C418-076025	76.0mm 3"	25mm	80mm	1	M

CODE	DESCRIPTION & SIZE	PACK QTY	DISCOUNT GROUP
<b>ACCESSORIES</b>			
C418-01025	REPLC Pilot Drill for TCT Holesaw 25mm Cutting Depth 5.0x26x67mm, 14.0mm Dia ONLY	1	M
C418-901125	REPLC Pilot Drill for TCT Holesaw 25mm Cutting Depth 6.0x26x67mm, for Dia 16.0-76.0mm	1	M
C418-901325	REPLC Spring for TCT Holesaw 25mm Cutting Depth, for Dia 16.0-76.0mm	1	M



## KEY FEATURES

Tungsten carbide tipped teeth provide excellent product life and cutting performance

Cutting depth of 25mm

3 flatted shank fits 10mm (3/8") and larger drill chucks

Complete assembly

Stop shoulder to prevent over drilling

Ejector spring quickly ejects waste material

Corded & coredless hand held drills up to 50mm

Pillar drills 14-76mm



\*Supplied without ejection spring



STAINLESS STEEL



WOOD



NAIL-EMBEDDED WOOD



PLASTIC



STEEL



NON-FERROUS METAL



# Arbors & Pilot Drills

## KEY FEATURES

Holesaw arbor come complete with HSS pilot drill

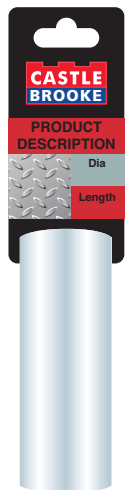

PACKAGING TYPE



CODE	DESCRIPTION & SIZE	PACK QTY	DISCOUNT GROUP
*C410-90011	A1C Arbor -9.5mm (3/8") Hex, suitable for Holesaws 14 - 30mm	1	M
*C410-90012	A2C Arbor - 11.0mm (7/16") Hex, suitable for Holesaws 32 - 210mm	1	M
*C410-90015	SDS+ A1C Arbor, Suitable for Holesaws 14 - 30mm	1	M
*C410-90016	SDS+ A2C Arbor, Suitable for Holesaws 32 - 210mm	1	M
*C410-90017	Quick-Change Arbor Set A1C & A2C, 8.5mm Hex, Suitable for Holesaws 14mm-210mm 5PCS	1	M
*C410-90018	Quick-Change Arbor Set A1C, 8.5mm Hex, Suitable for Holesaws 14mm-30mm 3PCS	1	M
*C410-90019	Quick-Change Arbor Set A2C, 8.5mm Hex, Suitable for Holesaws 32mm-210mm 3PCS	1	M
C410-90020	Quick-Change Arbor Adaptor A1C Holesaws 14mm-30mm	1	M
C410-90021	Quick-Change Arbor Adaptor A2C Holesaws 32mm-210mm	1	M
C410-90022	3.0mm Hex Key for quick-change Arbor	1	M
<b>PILOT DRILLS</b>			
C415-90016	P1 - 6.35x75mm (1/4" x 3.1/16") Pilot Drill Suitable For A1C-A2C	1	F
C415-90017	P2 - 6.35x100mm (1/4" x 4") Pilot Drill Suitable For A1C-A2C	1	F
C415-90018	Pilot Drill for Quick Change Arbor, Suitable for A1C & A2C 6.35x105mm	1	F
<b>EXTENSION BARS</b>			
C416-90006	300mm (12") Holesaw Extension Bar for a Castle Brooke, Morse A1 Arbor & Castle Brooke Quick-Change Arbor, to fit a 3/8" Chuck.	1	G
C416-90007	300mm (12") Holesaw Extension Bar for a Castle Brooke, Morse A2 Arbor, to fit a 1/2" Chuck	1	G

\* Pilot Drill included



C410-90017



# Holesaw Kits

CODE	DESCRIPTION & SIZE	PACK QTY	DISCOUNT GROUP
<b>ELECTRICIANS HOLESAW KIT</b>			
C410-90009	16, 20, 25, 32, 40, 51mm A1 & A2 Arbors, Pilot Drill & Adaptor Nut	1	M
<b>PLUMBERS HOLESAW KIT</b>			
C410-90010	22,29,35,44,51,57mm A1 & A2 Arbors, Pilot Drill & Adaptor Nut	1	M



+44 (0)114 261 7200  
info@castlebrooke.co.uk



WOOD



NAIL-EMBEDDED WOOD



PLASTIC



STEEL



NON-FERROUS METAL

# Morse Bi-Metal Master Cobalt Holesaws



CODE	DIAMETER	CUTTING DEPTH	PACK QTY	DISCOUNT GROUP
C416-0140	14.0mm 9/16"	49mm	1	G
C416-0160	16.0mm 5/8"	49mm	1	G
C416-0170	17.0mm 11/16"	49mm	1	G
C416-0190	19.0mm 3/4"	49mm	1	G
C416-0200	20.0mm 25/32"	49mm	1	G
C416-0210	21.0mm 13/16"	49mm	1	G
C416-0220	22.0mm 7/8"	49mm	1	G
C416-0240	24.0mm 15/16"	49mm	1	G
C416-0250	25.0mm 1"	49mm	1	G
C416-0270	27.0mm 1.1/16"	49mm	1	G
C416-0290	29.0mm 1.1/8"	49mm	1	G
C416-0300	30.0mm 1.3/16"	49mm	1	G
C416-0320	32.0mm 1.1/4"	49mm	1	G
C416-0330	33.0mm 1.5/16"	49mm	1	G
C416-0350	35.0mm 1.3/8"	49mm	1	G
C416-0370	37.0mm 1.7/16"	49mm	1	G
C416-0380	38.0mm 1.1/2"	49mm	1	G
C416-0400	40.0mm 1.9/16"	49mm	1	G
C416-0410	41.0mm 1.5/8"	49mm	1	G
C416-0430	43.0mm 1.11/16"	49mm	1	G
C416-0440	44.0mm (1.3/4"	49mm	1	G
C416-0460	46.0mm 1.13/16"	49mm	1	G
C416-0480	48.0mm 1.7/8"	49mm	1	G
C416-0500	50mm	49mm	1	G
C416-0510	51.0mm 2 inch"	49mm	1	G
C416-0520	52.0mm 2.1/16"	49mm	1	G
C416-0540	54.0mm 2.1/8"	49mm	1	G

CODE	DIAMETER	CUTTING DEPTH	PACK QTY	DISCOUNT GROUP
C416-0550	55.0mm 2.3/16"	49mm	1	G
C416-0570	57.0mm 2.1/4"	49mm	1	G
C416-0590	59.0mm 2.5/16"	49mm	1	G
C416-0600	60.0mm 2.3/8"	49mm	1	G
C416-0640	64.0mm 2.1/2"	49mm	1	G
C416-0650	65.0mm 2.9/16"	49mm	1	G
C416-0670	67.0mm 2.5/8"	49mm	1	G
C416-0700	70.0mm 2.3/4"	49mm	1	G
C416-0730	73.0mm 2.7/8"	49mm	1	G
C416-0750	75.0mm 2.15/16"	49mm	1	G
C416-0760	76.0mm 3"	49mm	1	G
C416-0790	79.0mm 3.1/8"	49mm	1	G
C416-0830	83.0mm 3.1/4"	49mm	1	G
C416-0860	86.0mm 3.3/8"	49mm	1	G
C416-0890	89.0mm 3.1/2"	49mm	1	G
C416-0920	92.0mm 3.5/8"	49mm	1	G
C416-0950	95.0mm 3.3/4"	49mm	1	G
C416-0980	98.0mm 3.7/8"	49mm	1	G
C416-1020	102.0mm 4"	49mm	1	G
C416-1050	105.0mm 4.1/8"	49mm	1	G
C416-1080	108.0mm 4.1/4"	49mm	1	G
C416-1110	111.0mm 4.3/8"	49mm	1	G
C416-1140	114.0mm 4.1/2"	49mm	1	G
C416-1210	121.0mm 4.3/4"	49mm	1	G
C416-1270	127.0mm 5"	49mm	1	G
C416-1400	140.0mm 5.1/2"	49mm	1	G
C416-1520	152.0mm 6"	49mm	1	G

## KEY FEATURES

Variable pitch tooth pattern which will clear dust more effectively and gives superior cutting performance.

**SUITABLE FOR** wood, nail embedded wood, plastic, steel, stainless steel and non-ferrous metals.

◆ **M42 (8% Cobalt) HSS Bi-Metal Cutting Edge**

**NOTE:** Holesaws do not include an arbor or pilot drill.



PACKAGING TYPE



STAINLESS STEEL



WOOD



NAIL-EMBEDDED WOOD



PLASTIC



STEEL



NON-FERROUS METAL

Please contact us for Tungsten Carbide Tipped.



# Morse Arbors & Pilot Drills

## KEY FEATURES

Holesaw arbors come complete with a HSS pilot drill.



CODE	DESCRIPTION & SIZE	PACK QTY	DISCOUNT GROUP
<b>ARBORS</b>			
C416-90001	A1 Arbor 9.5mm Hex with Pilot Drill, for Holesaws 14-30mm	1	G
C416-90002	A2 Arbor 12.7mm Hex with Pilot Drill, for Holesaws 32-152mm	1	G
<b>SDS ARBORS</b>			
C416-90011	SDS/A1 1/2 x 20 with Pilot Drill, for Holesaws 14-30mm	1	G
C416-90012	SDS/A2 5/8 UNF with Pilot Drill, for Holesaws 32-152mm	1	G
<b>EXTENSION BARS</b>			
C416-90006	300mm (12") Holesaw Extension Bar for a Castle Brooke, Morse A1 Arbor & Castle Brooke Quick-Change Arbor, to fit a 3/8" Chuck.	1	G
C416-90007	300mm (12") Holesaw Extension Bar for a Castle Brooke, Morse A2 Arbor, to fit a 1/2" Chuck	1	G



WOOD

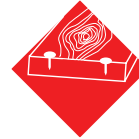

NAIL-EMBEDDED WOOD



PLASTIC



STEEL



NON-FERROUS METAL



# Power Planer Blades



CODE	DESCRIPTION & SIZE	PACK QTY	DISCOUNT GROUP
C470-0001	75.5mm blister pack 1 Pair	1 Pair	M
C470-0002	82.0mm blister pack 1 Pair	1 Pair	M
C470-0003	80.5mm blister pack 1 Pair	1 Pair	M

## KEY FEATURES

Tungsten carbide-tipped reversible planer blades.

PACKAGING TYPE



HARDWOOD



SOFTWOOD

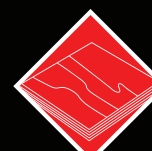

PLYWOOD

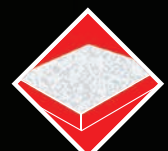

MDF

+44 (0)114 261 7200  
info@castlebrooke.co.uk



# Jigsaw Blades, Bosch T Type Shank



CODE	SIMILAR TO	TPI	OVERALL/WORKING LENGTH	MATERIAL TO CUT	APPLICATION	BLADE MATERIAL	PACK QTY	DISCOUNT GROUP
C440-0020	T118B	12	75/50mm	Metal	For cutting medium-thick sheet metals 2.5-6mm	HSS	5	J
C440-0017	T118A	21	75/50mm	Metal	For cutting thin sheet metals 1-3mm	HSS	5	J
C440-0022	T118G	32	75/50mm	Metal	For cutting very thin sheet metals 0.5-1.5mm	HSS	5	J
C440-0027	T318A	21	132/107mm	Metal	For cutting thin sheet metals 1-3mm, pipes + profiles, inc. aluminium dia. <65mm	HSS	5	J
C440-0029	T101D	6	100/75mm	Wood	For cutting softwood, chipboards, plywood, fibre boards 10-45mm	HCS	5	J
C440-0023	T111C	8	100/75mm	Wood	For cutting softwood 4-50mm, chipboards, plywood, fibre boards, quick cut	HCS	5	J
C440-0026	T101B	10	100/75mm	Wood	For cutting softwood, chipboards, plywood, fibre boards 3-30mm, plastics dia. <30mm	HCS	5	J
C440-0032	T144D	6	100/75mm	Wood	For cutting softwood 5-50mm, chipboards, woodcore plywood, fibre boards, quick cut	HCS	5	J
C440-0039	T101BR	10	100/75mm	Wood	For cutting softwood, chipboards, plywood, fibre boards 3-30mm, laminated panels	HCS	5	J
C440-0040	T344D	6	152/127mm	Wood	For cutting thick construction timber softwood 5-100mm, chipboards, plywood, fibre boards	HCS	5	J

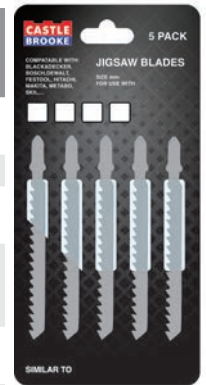

PACKAGING TYPE

# Reciprocating Saw Blades



CODE	SIMILAR TO	TPI	LENGTH x WIDTH x THICKNESS	WORKING LENGTH	MATERIAL TO CUT	APPLICATION	BLADE MATERIAL	PACK QTY	DISCOUNT GROUP
C445-0001	S922EF	18	150x19x0.9mm	130mm	Metal	For cutting thin sheet metals 1.5-4mm, pipes/profiles dia. <100mm	BIM	5	F
C445-0002	S1122EF	18	225x19x0.9mm	205mm	Metal	For cutting thin sheet metals 1.5-4mm, pipes/profiles dia. <175mm	BIM	5	F
C445-0003	S1122BF	14	225x19x0.9mm	205mm	Metal	For cutting thick sheet metals 3-8mm, solid pipes/profiles dia. <175mm, fast cut	BIM	5	F
C445-0004	S922VF	10/14	150x19x0.9mm	130mm	Wood/ Metal	For cutting wood with nails/ metal <100mm, sheet metals, pipes, aluminium profiles 3-10mm, plastics	BIM	5	F
C445-0005	S1022HF	10	200x19x0.9mm	180mm	Wood/ Metal	For cutting wood with nails/ metal <150mm, sheet metals, pipes, aluminium profiles 3-12mm, plastics	BIM	5	F
C445-0006	S1122VF	10/14	225x19x0.9mm	205mm	Wood/ Metal	For cutting wood with nails/ metal <250mm, sheet metals, pipes, aluminium profiles 3-10mm, plastics	BIM	5	F
C445-0007	S644D	6	150x19x1.25mm	130mm	Wood	For cutting construction timber, boards: chipboard, MDF, plywood, plastic	HCS	5	F
C445-0008	S2345X	6/10	200x19x1.25mm	180mm	Wood	For cutting construction timber, boards: chipboard, MDF, plywood, plastic, fine cuts	HCS	5	F
C445-0009	S1531L	5	240x19x1.50mm	220mm	Wood	For cutting green wood (tree cutting and pruning), coarse fast cut	HCS	5	F
C445-0010	S1344D	6	300x19x1.25mm	280mm	Wood	For cutting construction timber, boards: chipboard, MDF, plywood, plastic	HCS	5	F



PACKAGING TYPE

C446-0001

## TUNGSTEN CARBIDE TIPPED (TCT) RECIPROCATING BLADE

C446-0001	S1234MH	2	300x50x1.50mm	215mm	Masonry	For cutting fibre cement, poroton cement, porous concrete, red brick.	TCT cutting edge	1	F
-----------	---------	---	---------------	-------	---------	---	------------------	---	---

## RECIPROCATING SCRAPER BLADE

C447-0100			100mm (4") Scraper Blade	100mm (4")	-	For lifting tiles, carpets, plaster & floor screeding	-	1	F
-----------	--	--	-----------------------------	------------	---	---	---	---	---



C447-0100

◆ **Universal shank fits into virtually any machine**

High Carbon Steel (HCS) / High Speed Steel (HSS) / HSS Bi-Metal (BIM)



# Morse Bi-Metal Master Cobalt Reciprocating Saw Blades

CODE	MORSE CODE	TPI	LENGTH x WIDTH x THICKNESS	WORKING LENGTH	MATERIAL TO CUT	APPLICATION	PACK QTY	DISCOUNT GROUP
C450-0020	RB414T05	14	100x20x0.9mm	80mm	Metal	For cutting all machineable metals, inc stainless steel	5	F
C450-0022	RB418T05	18	100x20x0.9mm	80mm	Metal	For cutting all machineable metals, inc stainless steel	5	F
C450-0021	RB424T05	24	100x20x0.9mm	80mm	Metal	For cutting all machineable metals, inc stainless steel	5	F
C450-0007	RB614T05	14	150x20x0.9mm	130mm	Metal	For cutting all machineable metals, inc stainless steel	5	F
C450-0001	RB618T05	18	150x20x0.9mm	130mm	Metal	For cutting all machineable metals, inc stainless steel	5	F
C450-0009	RB624T05	24	150x20x0.9mm	130mm	Metal	For cutting all machineable metals, inc stainless steel	5	F
C450-0023	RB814T05	14	200x20x0.9mm	180mm	Metal	For cutting all machineable metals, inc stainless steel	5	F
C450-0003	RB818T05	18	200x20x0.9mm	180mm	Metal	For cutting all machineable metals, inc stainless steel	5	F
C450-0018	RB1218T05	18	300x20x0.9mm	280mm	Metal	For cutting all machineable metals, inc stainless steel	5	F
C450-0002	RB610T05	10	150x20x0.9mm	130mm	Wood/ Metal	For cutting all machineable metals, inc stainless steel, plastic, composites and all woods, inc nail embedded wood	5	F
C450-0004	RB61014T05	10/14	150x20x0.9mm	130mm	Wood/ Metal	For cutting all machineable metals, inc stainless steel, plastic, composites and all woods, inc nail embedded wood	5	F
C450-0011	RB81014T05	10-14	200x20x0.9mm	180mm	Wood/ Metal	For cutting all machineable metals, inc stainless steel, plastic, composites and all woods, inc nail embedded wood	5	F
C450-0024	RB8501014T05	10-14	200x20x1.3mm	180mm	Wood/ Metal	For cutting all machineable metals, inc stainless steel, plastic, composites and all woods, inc nail embedded wood	5	F
C450-0012	RB121014T05	10-14	300x20x0.9mm	280mm	Wood/ Metal	For cutting all machineable metals, inc stainless steel, plastic, composites and all woods, inc nail embedded wood	5	F
C450-0005	RB65006T05	6	150x20x1.3mm	130mm	Wood	For cutting all woods, composites, inc nail embedded wood	5	F
C450-0013	RB95006T05	6	225x20x1.3mm	205mm	Wood	For cutting all woods, composites, inc nail embedded wood	5	F
C450-0006	RB125006	6	300x20x1.3mm	280mm	Wood	For cutting all woods, composites, inc nail embedded wood	5	F

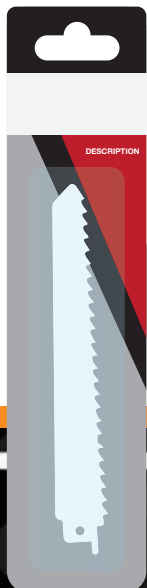

- ◆ **Universal shank fits into virtually any machine**
- ◆ **Bi-Metal M42 (8% Cobalt)**

PACKAGING TYPE

Please contact us for larger pack Qty's



STAINLESS STEEL



NAIL-EMBEDDED WOOD



STEEL



WOOD



PLASTIC

# Hacksaw Frames & Blades

CODE	DIAMETER	PACK QTY	DISCOUNT GROUP
<b>HACKSAW FRAMES</b>			
C430-0001	12" Hacksaw Frame + 24 TPI Bi-Metal Blade 45° & 90° Cutting Angles	1	M
C430-0003	6" Junior Hacksaw powder coated frame + Blade	1	M
C430-0004	6" Junior Hacksaw with plastic handle + Blade	1	M
<b>HACKSAW BLADES</b>			
C430-0006	18 TPI x 12" HSS Bi-Metal - Hanging Tube	10	M
C430-0007	24 TPI x 12" HSS Bi-Metal - Hanging Tube	10	M
C430-0008	32 TPI x 12" HSS Bi-Metal - Hanging Tube	10	M
C430-0019	6" Junior Blade Carbon Steel - Walled	10	M



STEEL



WOOD



PLASTIC



PACKAGING TYPES

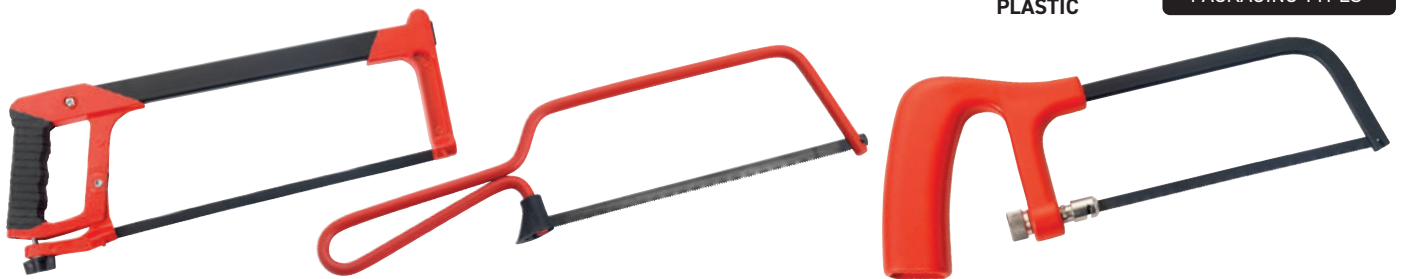

# Trimming Knife & Blades

## KEY FEATURES

Blades are manufactured from hardened and tempered Carbon steel with double ground edges to give efficient and long lasting cutting performance.



CODE	DESCRIPTION	PACK QTY	DISCOUNT GROUP
C460-0002	Heavy Duty Trimming Knife Blades (available in packs of 100)	1	J
C460-0003	Heavy Duty Trimming Knife Blades Safety Dispenser	10	J
C460-0004	Heavy Duty Trimming Knife Safety Dispenser	100	J
C460-0005	Heavy Duty 2 Notch Pointed Hook Blades (available in packs of 100)	1	J
C460-0006	Silver Retractable Trimming Knife Complete With 3 Blades	1	J



C460-0004



C460-0006



C460-0002



C460-0003

+44 (0)114 261 7200  
info@castlebrooke.co.uk



# Cold Chisels, Wrecking Bars and Crow Bars

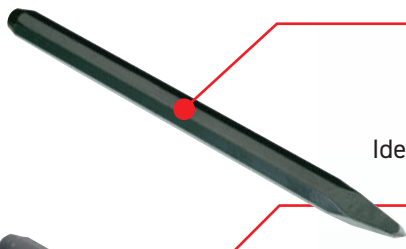

## CONCRETE POINT

Used for breaking up concrete floors, pathways etc.

## PRY OR PINCH BAR

Ideal for levering and aligning holes during steel construction.

## COLD CHISELS

Used for cutting, shaping or removing cold metals softer than the chisel itself, such as wrought iron, unhardened steel. Aluminium, brass, copper etc. Due to the alloy content in the raw material used, these can also be used on building materials.

## WRECKING BARS

Useful for leveraging timber and for pulling out nails from timber and dismantling wooden crates etc.

## BRICK BOLSTER

Used for cutting bricks, stone and paving slabs. The electrician's floorboard bolsters are used for cutting of tongue in laid tongued and grooved floorboarding or to remove a part of a board.

## CROW BAR

General levering and breaking and pointed tip for breaking concrete and stone.

## LINE PIN

Used in conjunction with a builders line for marking out position or aligning brickwork etc.

## GROOVED PLUGGING CHISEL

Designed for the removal of mortar and cement between bricks or for the complete removal of bricks.

## MASONS HAMMER HEAD BOLSTER/NICKER CHISEL

Suitable for split coping stones. The Nicker chisel has a thicker design than a brick bolster to be able to cut through stronger materials.

## SCUTCH COMB HOLDER

Designed for holding detachable stone dressing combs.

## MASONS HAMMER HEAD PITCHER CHISEL

Suitable for removing unwanted stone i.e. roughly chiselling a stone or masonry block down to the required size and pitch the surface to dress the stone as required.

◆ *A comprehensive range of hand tools for tough surfaces.*

+44 (0)114 261 7200  
info@castlebrooke.co.uk

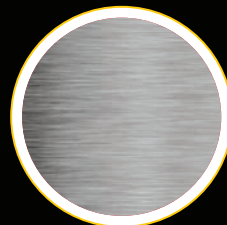

CODE	DESCRIPTION & SIZE	PACK QTY	DISCOUNT GROUP
<b>BRICK BOLSTERS</b>			
C260-0131	75mm (3")	1	H
C260-0210	75mm (3") Grippled	1	H
C260-0125	100mm (4")	1	H
C260-0179	100mm (4") Grippled	1	H
<b>ELECTRICIANS FLOORBOAR CHISELS</b>			
C260-0224	56mm (2.1/4")	1	H
C260-0241	56mm (2.1/4") Grippled	1	H
<b>COLD CHISELS</b>			
C261-90005	6 x 100mm (4" x 1/4")	1	H
C261-90013	6 x 150mm (6" x 1/4")	1	H
C261-90023	10 x 125mm (5" x 3/8")	1	H
C261-90032	10 x 150mm (6" x 3/8")	1	H
C261-90042	13 x 150mm (6"x1/2")	1	H
C261-90069	13 x 200mm (8" x 1/2")	1	H
C261-90071	13 x 250mm (10" x 1/2")	1	H
C261-90074	13 x 300mm (12" x 1/2")	1	H
C261-90077	13 x 450mm (18" x 1/2")	1	H
C261-90092	16 x 175mm (7" x 5/8")	1	H
C261-90098	16 x 250mm (10" x 5/8")	1	H
C261-90099	16 x 300mm (12" x 5/8")	1	H
C261-90100	16 x 450mm (18" x 5/8")	1	H
C261-90104	19 x 200mm (8" x 3/4")	1	H
C261-90119	19 x 250mm (10" x 3/4")	1	H
C261-90280	19x250mm (10" x 3/4") Grippled	1	H
C261-90129	19 x 300mm (12"x3/4")	1	H
C261-90283	19 x 300mm (12" x 3/4") Grippled	1	H
C261-90138	19 x 450mm (18"x3/4")	1	H
C261-90285	19 x 450mm (18" x 3/4") Grippled	1	H
C261-90149	19 x 600mm (24" x 3/4")	1	H
C261-90162	25 x 200mm (8" x 1")	1	H
C261-90175	25 x 250mm (10" x 1")	1	H
C261-90185	25 x 250mm (10" x 1") Grippled	1	H
C261-90195	25 x 300mm (12" x 1")	1	H
C261-90203	25 x 300mm (12" x 1") Grippled	1	H
C261-90215	25 x 450mm (18" x 1")	1	H
C261-90289	25 x 450mm (18" x 1") Grippled	1	H
C261-90223	25 x 600mm (24" x 1")	1	H
C261-90290	25 x 600mm(24" x 1") Grippled	1	H
<b>CONCRETE POINT</b>			
C261-90494	19 x 250mm (10" x 3/4")	1	H
<b>MASONS NICKER</b>			
C261-0026	50 x 213mm (8.1/2" x 2")	1	H
C261-0027	63 x 213mm (8.1/2" x 2.1/2")	1	H
<b>MASONS PITCHER</b>			
C261-0029	50 x 213mm (8.1/2" x 2")	1	H
C261-0030	63 x 213mm (8.1/2" x 2.1/2")	1	H

CODE	DESCRIPTION & SIZE	PACK QTY	DISCOUNT GROUP
<b>*COMB HOLDERS</b>			
C263-0018	25mm (1")	1	H
C263-0008	38mm (1.1/2")	1	H
<b>COMBS</b>			
C263-0003	25mm (1")	1	H
C263-0004	38mm (1.1/2")	1	H
<b>DROVES</b>			
C263-0005	25mm (1")	1	H
C263-0006	38mm (1.1/2")	1	H
<b>LINE PIN</b>			
C265-0002	150mm (6")	1	H
<b>PRY OR PINCH BAR</b>			
C264-0001	19mm x450mm (18"x3/4")	1	H
<b>GROOVED PLUGGING CHISEL</b>			
C260-0006	250mm (10")	1	H
<b>WRECKING BARS</b>			
C262-0001	12mm x 300mm (12" x 1/2")	1	H
C262-0002	16mm x 450mm (18"x5/8")	1	H
C262-0004	19mm x 600mm (24" x 3/4")	1	H
C262-0005	19mm x 750mm (30" x 3/4")	1	H
C262-0006	19mm x 900mm (36" x 3/4")	1	H
<b>CROW BARS</b>			
C260-0069	25 x 900mm (36"x 1")	1	H
C260-0072	28 x 1200mm (48"x 1.1/8")	1	H
C260-0074	32 x 1500mm (59" x 1.1/4")	1	H
C260-0076	38 x 1800mm (72" x 1.1/2")	1	H
<b>SAFETY GRIPS</b>			
C261-90448	16mm (5/8")	1	H
C261-90456	22mm (7/8")	1	H

**DURACUT** 



\*Comb not included

**CASTLE  
BROOKE**  
TOOLS (UK) LIMITED

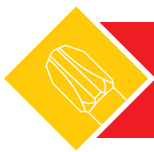

# Drill Chucks

## KEY FEATURES

All key chucks are supplied with a Chuck Key.

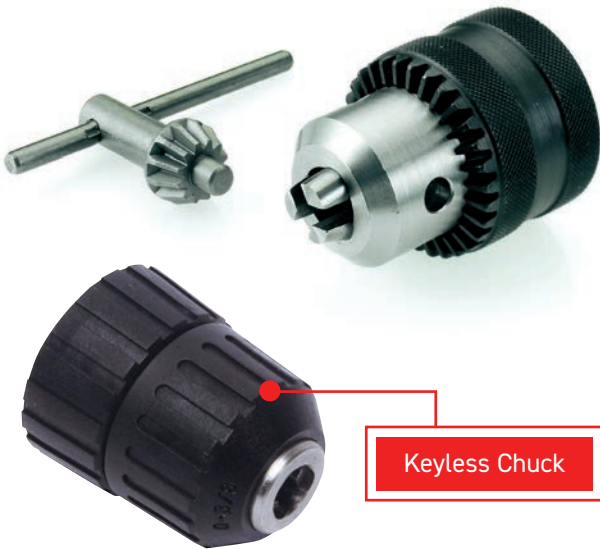

Keyless Chuck

**PLEASE NOTE:**  
No guarantee given to any drill chuck used with SDS hammer action.



PACKAGING TYPES  
PLEASE SPECIFY

CODE	DESCRIPTION & SIZE	PACK QTY	DISCOUNT GROUP
<b>LIGHT DUTY BOXED</b>			
C700-0497	2110F38 1-10mm 3/8"x24 UNF	1	J
C700-0498	2113F12 1.5-13mm 1/2"x20 UNF	1	J
<b>MEDIUM DUTY BOXED</b>			
C700-0500	2210F38 1-10mm 3/8"x24 UNF	1	J
C700-0502	2213F12 1.5-13mm 1/2"x20 UNF	1	J
<b>KEYLESS BOXED</b>			
C700-0504	2410F38 1-10mm 3/8"x24 UNF	1	J
C700-0505	2613F12 1.5-13mm 1/2"x20 UNF	1	J
<b>LIGHT DUTY BLISTER PACKED</b>			
C700-0507	2110F38B 1-10mm 3/8"x24 UNF	1	J
C700-0508	2113F12B 1.5-13mm 1/2"x20 UNF	1	J
C700-0509	2113SDSB 1.5-13mm 1/2"x20 UNF with SDS Adaptor	1	J
<b>MEDIUM DUTY BLISTER PACKED</b>			
C700-0510	2210F38B 1-10mm 3/8"x24 UNF	1	J
C700-0511	2213F12B 1.5-13mm 1/2"x20 UNF	1	J
C700-0512	2213SDSB 1.5-13mm 1/2"x20 UNF with SDS Adaptor	1	J
<b>KEYLESS BLISTER PACKED</b>			
C700-0513	2410F38B 1-10mm 3/8"x24 UNF	1	J
C700-0514	2613F12B 1.5-13mm 1/2"x20 UNF	1	J
C700-0515	2613SDSB 1.5-13mm 1/2"x20 UNF with SDS Adaptor	1	J



# SDS Plus Chuck Adaptors

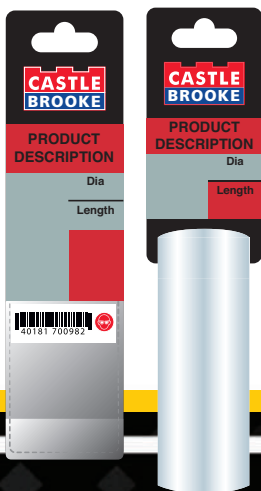

PACKAGING TYPES  
PLEASE SPECIFY

CODE	DESCRIPTION & SIZE	PACK QTY	DISCOUNT GROUP
C551-0001	SDSF12 1/2" x20 UNF Chuck Adaptor	1	F



+44 (0)114 261 7200  
info@castlebrooke.co.uk

# Industrial Wire Brushes



CODE	DESCRIPTION & SIZE	PACK QTY	DISCOUNT GROUP
<b>BENCH GRINDER WIRE WHEELS</b>			
C510-0001	150mm x 19mm	1	J
C510-0002	150mm x 25mm	1	J
C510-0003	200mm x 20mm	1	J
<b>CRIMPED CUP BRUSHES</b>			
C510-0006	75mm x M14 x 2.00	1	J
C510-0007	100mm x M14 x 2.00	1	J
C510-0008	120mm x M14 x 2.00	1	J
<b>TWIST KNOT CUP BRUSHES</b>			
C510-0012	65mm x M14 x 2.00	1	J
C510-0013	100mm x M14 x 2.00	1	J
C510-0014	125mm x M14 x 2.00	1	J
<b>END BRUSHES</b>			
C510-0016	25mm Brass Wire End brush with a 6mm Shank	1	J
<b>MIXED POWER BRUSHES FOR DRILLING MACHINES DISPLAY BOX</b>			
C510-0020	36pce Mixed Brass Wire Power Brushes for Drilling Machines	1	J
<b>HAND SCRATCH BRUSHES</b>			
C510-0017	Wood Handle 4 Row	1	J
C510-0019	Red-Plastic Handled Brass Plated Wire Brush	1	J
C510-0021	Red-Plastic Handled Brass Plated Wire Brush Display Box	24	J
C510-0022	Green-Plastic Handled Stainless Steel Wire Brush	1	J
C510-0023	Yellow-Plastic Handled Pure Brass Wire Brush	1	J
C510-0024	Blue-Plastic Handled Nylon Brush	1	J
C510-0025	Mixed Plastic Handled Brush Display Box, 7 x Blue, Green & Yellow	21	J



PACKAGING TYPE



**C510-0020**  
Contains  
50mm Cup Brushes x 10  
25mm End Brushes x 6  
50mm Wire wheels x 10  
75mm Wire Wheels x 10



## Tungsten Carbide Grit Mortar Rake

CODE	DESCRIPTION & SIZE	PACK QTY	DISCOUNT GROUP
C511-0001	8x40mm TCT Grit Mortar Rake M14 to Suit 115/125mm Grinders	1	J

Please Note: Not suitable for plunging - Drill a suitable sized pilot hole first.





# Drywall Sanding Discs

## KEY FEATURES

- Aluminium oxide grit
- Multihole system
- For sanding plaster walls & ceilings
- Hook & Loop backed perforated sanding discs
- C-weight paper
- 225mm diameter
- 16mm centre hole
- To suit the following models: GE 5/GE 5 R, GSE 5R, WSE 7 Vario Set, WSE 7 Vario Plus, WST 700 VV, WST 700 VV Plus, & WS702VEA

CODE	DIA	CENTRE HOLE DIAMETER	GRIT	PACK QTY	DISCOUNT GROUP
C850-225G080	225mm	16mm	80	50	PE
C850-225G100	225mm	16mm	100	50	PE
C850-225G120	225mm	16mm	120	50	PE
C850-225G220	225mm	16mm	220	50	PE





# Riveting Pliers



## KEY FEATURES

Heavy Duty Riveters have a 3-jaw mechanism which hold the rivet in a firmer grip to prevent the rivet from slipping and ensure ease of use.

The jaws last longer and are less likely to be clogged with metal dust.

CODE	DESCRIPTION & SIZE	PACK QTY	DISCOUNT GROUP
C520-0002	802 Hand Riveter 3,4,5mm	1	F
C520-0003	812 Challenger Hand Riveter 2.4, 3,4,5mm	1	F
C520-0004	810 Compact Hand Riveter with spring 2.4, 3,4,5mm	1	F
C520-0006	832 Hand Riveter Set - 70 Rivets in carry case.	1	F
C520-0007	805b Lazy Tong Riveter 2.4, 3,4,5,6mm	1	F
<b>ALUMINIUM RIVETS</b>			
C520-0012	3.2 x 6mm - Red	50	F
C520-0013	3.2 x 9mm - Red	50	F
C520-0014	3.2 x 12mm - Red	50	F
C520-0015	3.8 x 6mm - Green	50	F
C520-0011	3.8 x 10mm - Green	50	F
C520-0016	3.8 x 12mm - Green	50	F
C520-0017	4.8 x 6mm - Yellow	50	F
C520-0018	4.8 x 10mm -Yellow	50	F
C520-0019	4.8 x 12mm - Yellow	50	F





# Screwdriver Bits, Bit Holders & Screw Extractors

CODE SINGLE	SIZE	CODE BOXED IN 10's	DISCOUNT GROUP
<b>DRIVER BITS</b>			
C530-0057	PH No.2 - 25mm Long	C530-0057/10	M
C530-0072	PZ No.2 - 25mm Long	C530-0072/10	M
C530-0075	PZ No.3 - 25mm Long	C530-0075/10	M
C530-0127	T30 Torx - 25mm Long	C530-0127/10	M
C530-0016	PZ No.2 150mm long - Walled		M
<b>IMPACT DRIVER BITS</b>			
C530-0058	PH No.2 - 25mm Long	C530-0058/10	M
C530-0061	PH No.3 - 25mm Long	C530-0061/10	M
C530-0070	PZ No.1 - 25mm Long	C530-0070/10	M
C530-0073	PZ No.2 - 25mm Long	C530-0073/10	M
C530-0073SET	PZ No.2 - 25mm Long Display Box - 12 Sets x 10Pc		M
C530-0076	PZ No.3 - 25mm Long	C530-0076/10	M
C530-0122	T20 Torx - 25mm Long	C530-0122/10	M
C530-0124	T25 Torx - 25mm Long	C530-0124/10	M
C530-0130	T30 Torx - 25mm Long	C530-0130/10	M
C530-0150	PH No.2 - 50mm Long	C530-0150/10	M
C530-0152	PH No.3 - 50mm Long	C530-0152/10	M
C530-0160	PZ No.2 - 50mm Long	C530-0160/10	M



BOXED IN 10's  
PACKAGING TYPE

## DRIVER BITS

High grade chrome-vanadium steel through hardened forged bits.

## IMPACT BITS

With enormous durability has the same features as torque bit. The bit features are increased on the extended shaft even further. Impact bits are specially manufactured for use in a very strong impact pneumatic wrenches/electric tools.

Bits are made of special molybdenum-vanadium steel with a very long and sensitive torsion zone in the middle of the bit. Professionally designed process of heat working ensures high solid at the bit tip with good elasticity in torsion zone.



 PH = PHILIPS

 PZ = POZI

 T = TORX



+44 (0)114 261 7200  
info@castlebrooke.co.uk

CODE	SIZE & DESCRIPTION	PACK QTY	DISCOUNT GROUP
<b>MAGNETIC BIT HOLDERS</b>			
C532-0016	Magnetic Bit Holder 1/4" x 60mm	1	M
C532-1016JAR	10Pc Magnetic Bit Holder 1/4"x60mm Display Jar	1	M
C532-2516JAR	25Pc Magnetic Bit Holder 1/4"x60mm Display Jar	1	M
C531-0017	Quick-Change Bit Holder 1/4"x60mm Impact rated for Impact Drivers	1	M
C531-0031JAR	10Pc Quick-Change Bit Holder 1/4"x60mm Display Jar	1	M
C531-0029JAR	25Pc Quick-Change Bit Holder 1/4"x60mm Display Jar	1	M
C531-0018	Magnetic Bit Holder Screw Guide Sleeve 1/4" Hex 80mm Closed, 110mm Extended	1	M
C531-0026	Magnetic Bit Holder 1/4"x65mm	1	M
C531-0027	Magnetic Bit Holder Flex 1/4"x225mm	1	M
C531-0028	SDS Plus Quick-Change Bit Holder, 65mm, Impact Rated	1	M
C531-0030	Quick-Change Bit Holder, 1/4" x 250mm Ext Rod, Impact Rated	1	M
C537-0000	Screw Extractor Set 6Pc Range 3-22mm (No.1-No.6)	1	M

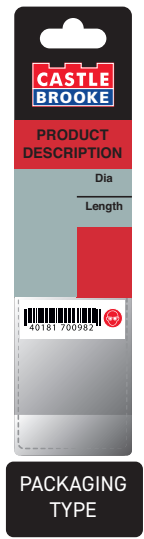

(C537-0000)



**MAGNETIC FLEX  
225mm**

Magnetic bit holder has a depth adjusting collar for use in drywall applications.  
(C531-0027)



**MAGNETIC BIT  
HOLDER  
SCREW GUIDE  
SLEEVE**

1/4" Hex,  
80mm Closed,  
110mm Extended.  
(C531-0018)



**MAGNETIC 65mm  
BIT HOLDER**  
Has a depth  
adjusting collar for use  
in drywall applications.  
(C531-0026)



**65mm SDS PLUS  
BIT HOLDER**  
(C531-0028)



**QUICK-CHANGE  
BIT HOLDER**  
(C531-0017)



**MAGNETIC  
BIT HOLDER**  
(C532-0016)

CODE	SIZE & DESCRIPTION	PACK QTY	DISCOUNT GROUP
<b>63PC COMBINATION DRILL &amp; DRIVE BIT SET</b>			

C900-0063 6 x HSS drill bits with titanium coating, sizes: - 2mm, 3mm, 4mm, 5mm, 6mm, 8mm  
6 x Masonry drill bits, sizes: - 3mm, 4mm, 5mm, 6mm, 7mm, 8mm  
6 x Centre spur wood drill bits, sizes: -3mm, 4mm, 5mm, 6mm, 7mm, 8mm  
3 x Flat wood drill bits, sizes: -13mm, 16mm, 19mm  
4 x Nutdrivers, sizes: - 5mm, 6mm, 7mm, 8mm  
30 x 25mm screwdriver bits, sizes  
> 5 x Slotted: 3mm, 4mm, 5mm, 6mm x 2pcs  
> 5 x Phillips: PH0, PH1, PH2 x 2pcs, PH3  
> 4 x Pozzi: PZ1, PZ2 x 2pcs, PZ3  
> 6 x Torx: T10, T15, T20, T25, T27, T30  
> 7 x Hex: 1.5mm, 2mm, 2.5mm, 3mm, 4mm, 5mm, 6mm  
> 3 x Square: SQ1, SQ2, SQ3  
4 x Holesaws, sizes: 32mm, 38mm, 44mm, 54mm  
1 x Countersink : 12.0mm , 1 x Magnetic bit holder  
1 x Screw finder 1 x Holesaw arbor



**PACKAGING TYPE**





# Magnetic Nut Setters

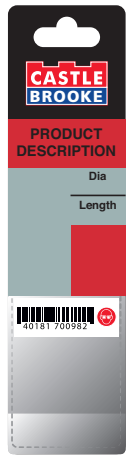

PACKAGING TYPE



DISPLAY JAR

CODE	SIZE	OVERALL LENGTH	PACK QTY	DISCOUNT GROUP
C535-0001	5.0mm	65mm	1	R
C535-0002	5.5mm	65mm	1	R
C535-0003	6.0mm	65mm	1	R
C535-0004	7.0mm	65mm	1	R
C535-0005	8.0mm	65mm	1	R
C535-0006	10.0mm	65mm	1	R
C535-0007	13.0mm	65mm	1	R
C535-0008	1/4"	65mm	1	R
C535-0009	3/8"	65mm	1	R
C535-0010	8.0mm x65mm	65mm	1	R
C535-1008JAR	8.0mm Display Jar 10Pc	65mm	1	R
C535-2508JAR	8.0mm Display Jar 25Pc	65mm	1	R

◆ 1/4" shank for hexagon headed bolts, screw and nuts.



# Bi-Hex Tek Screw Adaptor

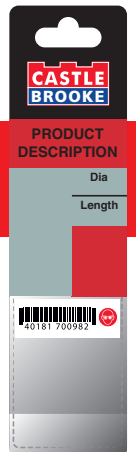
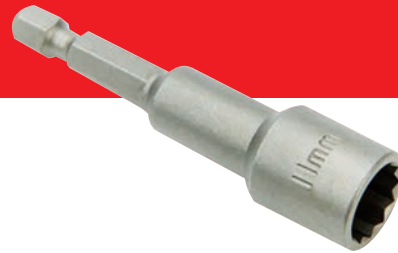

PACKAGING TYPE

CODE	SIZE	OVERALL LENGTH	PACK QTY	DISCOUNT GROUP
C535-0011	11mm	65mm	1	R

◆ 1/4" shank ideal for use with plastic intergrated self drill screw



# Pro Power Tape Measures - 5.0mtr/16ft



## KEY FEATURES

- Metric & Imperial
- Easy lock
- Easy release
- 30% thicker blade
- 19mm blade width
- Horizontal stand-out length 1.85mtr
- Vertical stand-out length 2.95mtr
- EC Class II

CODE	DESCRIPTION & SIZE	PACK QTY	DISCOUNT GROUP
C515-0001	5.0mtr/16ft Pro Power Tape Measure Metric/Imperial	1	D
C515-0001DB	5.0mtr/16ft Pro Power Tape Measure Metric/Imperial - Display Box	12	D



DISPLAY BOX



PACKAGING TYPE

# Cartridge Tool Consumables



## KEY FEATURES

Drive Pins/Nails with Plastic Washer & Head Dia 8.0mm To Suit - DX460

CODE	SIZE	PACK QTY	DISCOUNT GROUP
80011	3.75x16mm Knurled	100	PE
80012	3.75x19mm Knurled	100	PE
80013	3.75x22mm Knurled	100	PE
80014	3.75x27mm Smooth	100	PE
80015	3.75x32mm Smooth	100	PE
80016	3.75x37mm Smooth	100	PE
80017	3.75x42mm Smooth	100	PE
80018	3.75x47mm Smooth	100	PE
80019	3.75x52mm Smooth	100	PE
80102	3.75x57mm Smooth	100	PE
80079	3.75x62mm Smooth	100	PE
80081	3.75x72mm Smooth	100	PE



## KEY FEATURES

Drive Pins/Nails with Metal Washer Dia 12.0mm Head Dia 6.0mm To Suit - DX450

CODE	SIZE	PACK QTY	DISCOUNT GROUP
80103	3.75x16mm Knurled	100	PE
80025	3.75x19mm Knurled	100	PE
80026	3.75x22mm Knurled	100	PE
80027	3.75x27mm Smooth	100	PE
80028	3.75x32mm Smooth	100	PE
80029	3.75x37mm Smooth	100	PE
80030	3.75x42mm Smooth	100	PE
80031	3.75x47mm Smooth	100	PE
80032	3.75x52mm Smooth	100	PE
80104	3.75x57mm Smooth	100	PE
80083	3.75x62mm Smooth	100	PE
80084	3.75x72mm Smooth	100	PE
80105	3.75x82mm Smooth	100	PE
80128	3.75x90mm Smooth	100	PE
80106	3.75x97mm Smooth	100	PE



## KEY FEATURES

Drive Pins/Nails with Magazine Strip Head Dia 8.0mm To Suit - DX5, DX A40 & DX A41

CODE	SIZE	PACK QTY	DISCOUNT GROUP
80020	3.75x16mm Knurled	100	PE
80021	3.75x19mm Knurled	100	PE
80022	3.75x22mm Knurled	100	PE
80023	3.75x27mm Smooth	100	PE
80024	3.75x32mm Smooth	100	PE
80065	3.75x42mm Smooth	100	PE
80066	3.75x52mm Smooth	100	PE
80067	3.75x62mm Smooth	100	PE
80087	3.75x72mm Smooth	100	PE



## KEY FEATURES

Winchester Cartridges To Suit - DX5, DXA40, DXA41, DX450 & DX460

CODE	SIZE	PACK QTY	DISCOUNT GROUP
80071	Green - Low Strength	100	PE
80072	Yellow - Low/Medium Strength	100	PE
80073	Red - Medium/High	100	PE
80074	Black - Extra High	100	PE



# Hasps, Staples & Padlocks

CODE	SIZE	PACK QTY	DISCOUNT GROUP
<b>HEAVY DUTY HASPS &amp; STAPLES - OPEN TYPE</b>			
C570-0002	200x50mm (8"x2")	1	D
C570-0003	250x50mm (10"x2")	1	D
C570-0013	150x50mm (6"x2") Vertical	1	D
<b>HEAVY DUTY HASPS &amp; STAPLES - SAFETY TYPE</b>			
C570-0006	89x28mm (3.1/2"x1.1/8")	1	D
C570-0007	89x32mm (3.1/2"x1.1/2")	1	D
C570-0008	115x32mm (4.1/2"x1.1/2")	1	D
C570-0009	140x32mm (5.1/2"x1.1/2")	1	D
C570-0010	178x50mm (7"x2")	1	D

## KEY FEATURES

5mm thick - all steel construction.  
 Hardened and welded hinge pin and staple.  
 Durable backed paint finish.

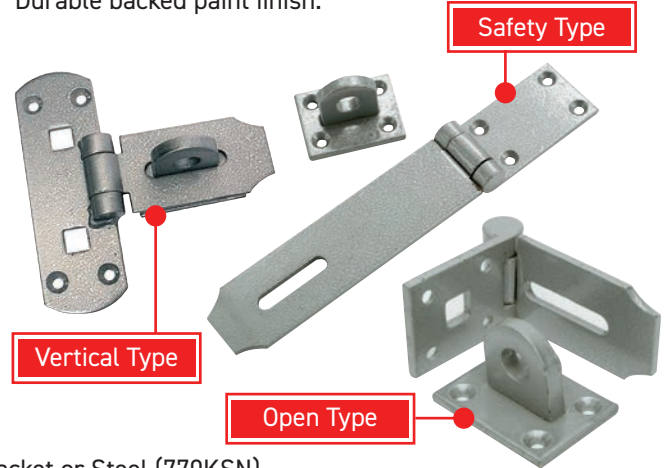

## KEY FEATURES

Solid brass (770FB) lock body with a chrome plated hardened steel jacket or Steel (770KSN).  
 Triple plated hardened steel locking bolt.  
 6 pin tumbler brass cylinder. The first pin is composed of hardened steel to guard against drilling.  
 Supplied with 2 nickel plated brass keys, key removable only in the locked position.

CODE	SIZE	PACK QTY	DISCOUNT GROUP
<b>ARMORED BLOCK LOCK</b>			
C562-0001	Wide-80mm, Height-66mm, Depth-27mm, Shackle Dia-11mm & Shackle clearance 30x18mm (KA)	1	D

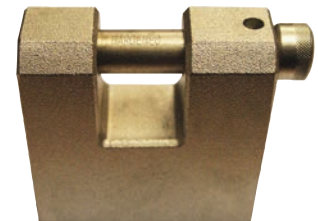

CODE	SIZE	PACK QTY	DISCOUNT GROUP
<b>SPACE LOCK</b>			
C561-0001	70mm Dia (KA)	1	D

## KEY FEATURES

Laser-welded stainless steel body.  
 Hardened steel shackle that provides tough bolt cutter and hacksaw resistance.  
 Double locking protection.  
 Brass cylinder with 5 pin tumblers.  
 Supplied with 2 nickel plated brass keys.



CODE	SIZE	PACK QTY	DISCOUNT GROUP
<b>BRASS PADLOCKS</b>			
C560-0001	20mm (KA)	1	D
C560-0002	25mm (KA)	1	D
C560-0003	30mm (KA)	1	D
C560-0005	40mm (KA)	1	D
C560-0006	40mm (KA) Long Shackle	1	D
C560-0008	50mm (KA)	1	D
C560-0010	60mm (KA)	1	D

## KEY FEATURES

Solid brass body.  
 Double locking.  
 Hardened steel shackle.  
 Rustproof interior.  
 Supplied with 2 keys.



# Carbide Burrs - Double Cut

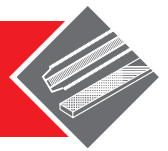

## KEY FEATURES

Deburring and polishing of cast iron, cast steel, carbon steel, alloy steel and stainless steel etc.

CODE	DIAMETER	WORKING LENGTH	OVERALL LENGTH	SHANK DIA	PACK QTY	DISCOUNT GROUP
<b>CYLINDER W/OUT END CUT - A SHAPE</b>						
5785-06016006	6.0mm	16.0mm	50.0mm	6.0mm	1	W
5785-10019006	10.0mm	19.0mm	65.0mm	6.0mm	1	W
5785-12719006	12.7mm	19.0mm	65.0mm	6.0mm	1	W
<b>CYLINDER WITH END CUT - B SHAPE</b>						
5784-06016006	6.0mm	16.0mm	50.0mm	6.0mm	1	W
5784-08019006	8.0mm	19.0mm	65.0mm	6.0mm	1	W
5784-10019006	10.0mm	19.0mm	65.0mm	6.0mm	1	W
5784-12719006	12.7mm	19.0mm	65.0mm	6.0mm	1	W
<b>BALL NOSED CYLINDER - C SHAPE</b>						
5781-06016006	6.0mm	16.0mm	50.0mm	6.0mm	1	W
5781-08019006	8.0mm	19.0mm	65.0mm	6.0mm	1	W
5781-10019006	10.0mm	19.0mm	65.0mm	6.0mm	1	W
5781-12719006	12.7mm	19.0mm	65.0mm	6.0mm	1	W
5781-12725406	12.7mm	25.4mm	70.0mm	6.0mm	1	W
<b>BALL - D SHAPE</b>						
5788-12011006	12.0mm	11.0mm	51.00mm	6.0mm	1	W
5788-16014006	16.0mm	14.0mm	58.00mm	6.0mm	1	W
<b>BALL NOSED TREE - F SHAPE</b>						
5782-10019006	10.0mm	19.0mm	65.0mm	6.0mm	1	W
5782-12025406	12.0mm	25.4mm	70.0mm	6.0mm	1	W
<b>TREE - G SHAPE</b>						
5787-06016006	6.0mm	16.0mm	50.0mm	6.0mm	1	W
5787-10019006	10.0mm	19.0mm	65.0mm	6.0mm	1	W
5787-12719006	12.7mm	19.0mm	65.0mm	6.0mm	1	W
5787-12725406	12.7mm	25.4mm	70.0mm	6.0mm	1	W
<b>FLAME - H SHAPE</b>						
5786-06014006	6.0mm	14.0mm	50.0mm	6.0mm	1	W
5786-08019006	8.0mm	19.0mm	65.0mm	6.0mm	1	W
5786-12732006	12.7mm	32.0mm	70.0mm	6.0mm	1	W
<b>BALL NOSED CONE - L SHAPE</b>						
5780-06016006	6.0mm	16.0mm	50.0mm	6.0mm	1	W
5780-10019006	10.0mm	19.0mm	65.0mm	6.0mm	1	W
5780-12030006	12.0mm	30.0mm	76.0mm	6.0mm	1	W
<b>CONE - M SHAPE</b>						
5783-06019006	6.0mm	19.0mm	50.0mm	6.0mm	1	W
5783-12719006	12.7mm	19.0mm	65.0mm	6.0mm	1	W
5783-12722006	12.7mm	22.0mm	70.0mm	6.0mm	1	W



CODE	SIZE & DESCRIPTION	PACK QTY	DISCOUNT GROUP
<b>10PC CARBIDE BURR SET DOUBLE</b>			
C5793-0010	2x A shape cylinder without end cut: 10x19x65x6mm, 12.7x19x65x6mm 2x C shape ball nosed cylinder: 10x19x65x6mm, 12.7x19x65x6mm 1x D shape ball: 12x11x51x6mm 2x F shape ball nosed tree: 10x19x65x6mm, 12.0x19x65x6mm 2x G shape tree: 10x19x65x6mm, 12.7x19x65x6mm 1x M shap cone: 12.7x19x65x6mm	1	W



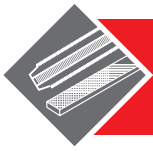

# HSS Taps & Sets - Metric Coarse

## SUITABLE FOR

Hand tapping of through or blind holes in alloyed and non-alloyed steel, cast steel, cast iron, non-ferrous metals.

## KEY FEATURES

- ◆ **Manufactured to ISO 529**
- ◆ **M2 Steel**
- ◆ **Set contains - Taper tap, Second tap & Bottom tap.**

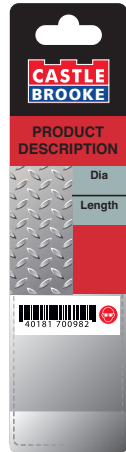

PACKAGING TYPE SINGLE



PACKAGING TYPE SETS

CODE	DIAMETER & PITCH	PACK QTY	DISCOUNT GROUP
5501-0030	M3.0x.50 SET	1	W
5501-00301	M3.0x.50 TAPER	1	W
5501-00302	M3.0x.50 SECOND	1	W
5501-00303	M3.0x.50 BOTTOM	1	W
5501-0035	M3.5x.60 SET	1	W
5501-00351	M3.5x.60 TAPER	1	W
5501-00352	M3.5x.60 SECOND	1	W
5501-00353	M3.5x.60 BOTTOM	1	W
5501-0040	M4.0x.70 SET	1	W
5501-00401	M4.0x.70 TAPER	1	W
5501-00402	M4.0x.70 SECOND	1	W
5501-00403	M4.0x.70 BOTTOM	1	W
5501-0045	M4.5x.75 SET	1	W
5501-00451	M4.5x.75 TAPER	1	W
5501-00452	M4.5x.75 SECOND	1	W
5501-00453	M4.5x.75 BOTTOM	1	W
5501-0050	M5.0x.80 SET	1	W
5501-00501	M5.0x.80 TAPER	1	W
5501-00502	M5.0x.80 SECOND	1	W
5501-00503	M5.0x.80 BOTTOM	1	W
5501-0060	M6.0x1.0 SET	1	W
5501-00601	M6.0x1.0 TAPER	1	W
5501-00602	M6.0x1.0 SECOND	1	W
5501-00603	M6.0x1.0 BOTTOM	1	W
5501-0080	MC8.0x1.25 SET	1	W
5501-00801	M8.0x1.25 TAPER	1	W
5501-00802	M8.0x1.25 SECOND	1	W
5501-00803	M8.0x1.25 BOTTOM	1	W
5501-0100	M10.0x1.5 SET	1	W
5501-01001	M10.0x1.5 TAPER	1	W

◆ See tap & drill sets on page 5

◆ See recommended tapping and drilling sizes on page 1

Please contact us for more sizes and thread types.  
+44 (0)114 261 7200  
info@castlebrooke.co.uk



NON-FERROUS METAL



STEEL



ALUMINIUM



## HSS Dies - Metric Coarse



### SUITABLE FOR

Threading in alloyed and non-alloyed steel, cast steel, cast iron, non-ferrous metals.



CODE	DIAMETER & PITCH	PACK QTY	DISCOUNT GROUP
5501-01002	M10.0x1.5 SECOND	1	W
5501-01003	M10.0x1.5 BOTTOM	1	W
5501-0120	M12.0x1.75 SET	1	W
5501-01201	M12.0x1.75 TAPER	1	W
5501-01202	M12.0x1.75 SCND	1	W
5501-01203	M12.0x1.75 BOTTOM	1	W
5501-0140	M14.0x2.0 SET	1	W
5501-01401	M14.0x2.0 TAPER	1	W
5501-01402	M14.0x2.0 SECOND	1	W
5501-01403	M14.0x2.0 BOTTOM	1	W
5501-0160	M16.0x2.0 SET	1	W
5501-01601	M16.0x2.0 TAPER	1	W
5501-01602	M16.0x2.0 SECOND	1	W
5501-01603	M16.0x2.0 BOTTOM	1	W
5501-0180	M18.0x2.5 SET	1	W
5501-01801	M18.0x2.5 TAPER	1	W
5501-01802	M18.0x2.5 SECOND	1	W
5501-01803	M18.0x2.5 BOTTOM	1	W
5501-0200	M20.0x2.5 SET	1	W
5501-02001	M20.0x2.5 TAPER	1	W
5501-02002	M20.0x2.5 SECOND	1	W
5501-02003	M20.0x2.5 BOTTOM	1	W
5501-0220	M22.0x2.5 SET	1	W
5501-02201	M22.0x2.5 TAPER	1	W
5501-02202	M22.0x2.5 SECOND	1	W
5501-02203	M22.0x2.5 BOTTOM	1	W
5501-0240	M24.0x3.0 SET	1	W
5501-02401	M24.0x3.0 TAPER	1	W
5501-02402	M24.0x3.0 SECOND	1	W
5501-02403	M24.0x3.0 BOTTOM	1	W

CODE	DIAMETER & PITCH & OVERALL DIAMETER	PACK QTY	DISCOUNT GROUP
6210-0009	M3.0x0.50x13/16"	1	V
6210-0010	M3.5x0.60x13/16"	1	V
6210-0011	M4.0x0.70x13/16"	1	V
6210-0022	M5.0x0.80x1"	1	V
6210-0023	M6.0x1.00x1"	1	V
6210-0025	M8.0x1.25x1"	1	V
6210-0027	M10.0x1.50x1"	1	V
6210-0046	M12x1.75x1-1/2"	1	V
6210-0047	M14x2.00x1-1/2"	1	V
6210-0048	M16x2.00x1-1/2"	1	V
6210-0049	M18x2.50x1-1/2"	1	V
6210-0050	M20x2.50x1-1/2"	1	V
6210-0066	M22x2.50x2"	1	V
6210-0067	M24x3.00x2"	1	V



PACKAGING TYPE



## Thread Repair Kit M5-M12 110PCS

CODE	SIZE & DESCRIPTION	PACK QTY	DISCOUNT GROUP
<b>THREAD REPAIR KIT M5-M12 110PCS</b>			
6480-0512	<ul style="list-style-type: none"> <li>• 25PCS helicoil thread inserts M5 x 0.8 x 6.7mm</li> <li>• 25PCS helicoil thread inserts M6 x 1.0 x 8mm</li> <li>• 25PCS helicoil thread inserts M8 x 1.25 x 10.8mm</li> <li>• 25PCS helicoil thread inserts M10 x 1.5 x 13.5mm</li> <li>• 10PCS helicoil thread inserts M12 x 1.75 x 16.3mm</li> <li>• 5PCS HSS Twist Drills 5.2, 6.2, 8.3, 10.3, 12.4mm</li> <li>• 5PCS HSS Taps M5x0.8, M6x1.0, M8x1.25, M10x1.5, M12x1.75</li> <li>• 5PCS installation tools</li> <li>• 5PCS Break Pin Tools</li> <li>• 1PC 2mm Hex Key</li> </ul>	1	W



See page 2 for cutting oil

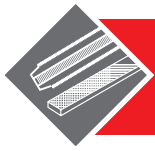

# Tap Wrenches & Die Stock Holders

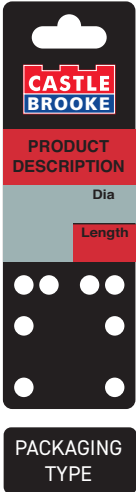
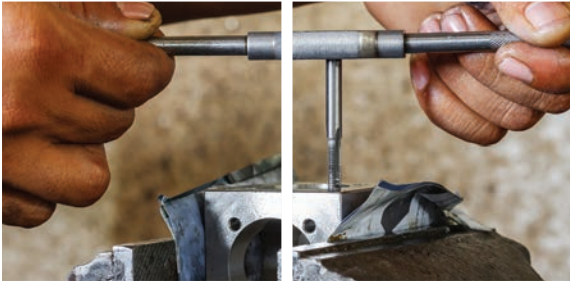

CODE	DIAMETER & PITCH & OVERALL DIAMETER	PACK QTY	DISCOUNT GROUP
<b>ADJUSTABLE TAP WRENCHES-STEEL BODY</b>			
C655-0009	ATW/1 M2 - M6 taps	1	J
C655-0010	ATW/2 M2 - M12 taps	1	J
C655-0011	ATW/3 M4 - M14 taps	1	J
C655-0012	ATW/4 M6 - M20 taps	1	J
<b>T TYPE TAP WRENCHES</b>			
C655-0015	TW/1/16 - 5/32" M1-M6 taps	1	J
C655-0016	TW/5/32" - 1/4" M4-M8 taps	1	J
C655-0017	TW/1/4" - 1/2" M6-M12 taps	1	J
<b>RATCHET TAP WRENCHES</b>			
C655-0023	TWR/5/32" - 1/4" M4-M6 taps	1	J
C655-0022	TWR/1/4" - 1/2" M6-M12 taps	1	J
<b>DIE STOCK HOLDERS</b>			
C656-0004	13/16" die	1	F
C656-0005	1" die	1	F
C656-0003	1.5/16" die	1	F
C656-0002	1.1/2" die	1	F
C656-0001	2" die	1	F

Adjustable Tap Wrench with steel body

Die Stock Holder



Ratchet Tap Wrench

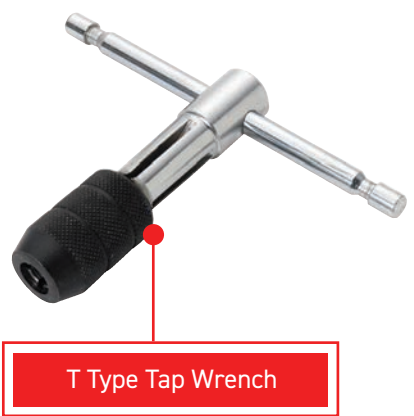

T Type Tap Wrench

# Calipers & Dividers

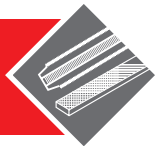

CODE	SIZE	PACK QTY	DISCOUNT GROUP
<b>INTERNAL SPRING CALIPERS</b>			
C660-0010	3"	1	J
C660-0011	4"	1	J
C660-0012	6"	1	J
C660-0013	8"	1	J
C660-0014	10"	1	J
C660-0015	12"	1	J
<b>EXTERNAL SPRING CALIPERS</b>			
C660-0016	3"	1	J
C660-0017	4"	1	J
C660-0018	6"	1	J
C660-0019	8"	1	J
C660-0020	10"	1	J
C660-0021	12"	1	J
<b>SPRING DIVIDERS</b>			
C660-0022	3"	1	J
C660-0023	4"	1	J
C660-0024	6"	1	J
C660-0025	8"	1	J
C660-0026	10"	1	J
C660-0027	12"	1	J
<b>INTERNAL FIRM JOINT CALIPERS</b>			
C660-0031	4"	1	J
<b>EXTERNAL FIRM JOINT CALIPERS</b>			
C660-0028	6"	1	J
C660-0032	8"	1	J
<b>JENNY CALIPERS</b>			
C660-0043	6"	1	J

Calipers and Dividers are amongst the oldest comparison measuring tools. Calipers are designed for taking transfer measurements or for making comparisons between external and internal measurements. These are used in conjunction with a precision rule, micrometer, caliper etc.

Dividers are used for marking out on steel or for transferring measurements from master templates.

These are manufactured from high grade steel and have a polished finish. The legs pivot on a roller and are tensioned by a bow spring.

The adjustment for measuring is made by means of an adjusting nut which allows for fine settings.

Caliper size refers to the distance from the fulcrum to the end of the leg measuring capacity is the same as size

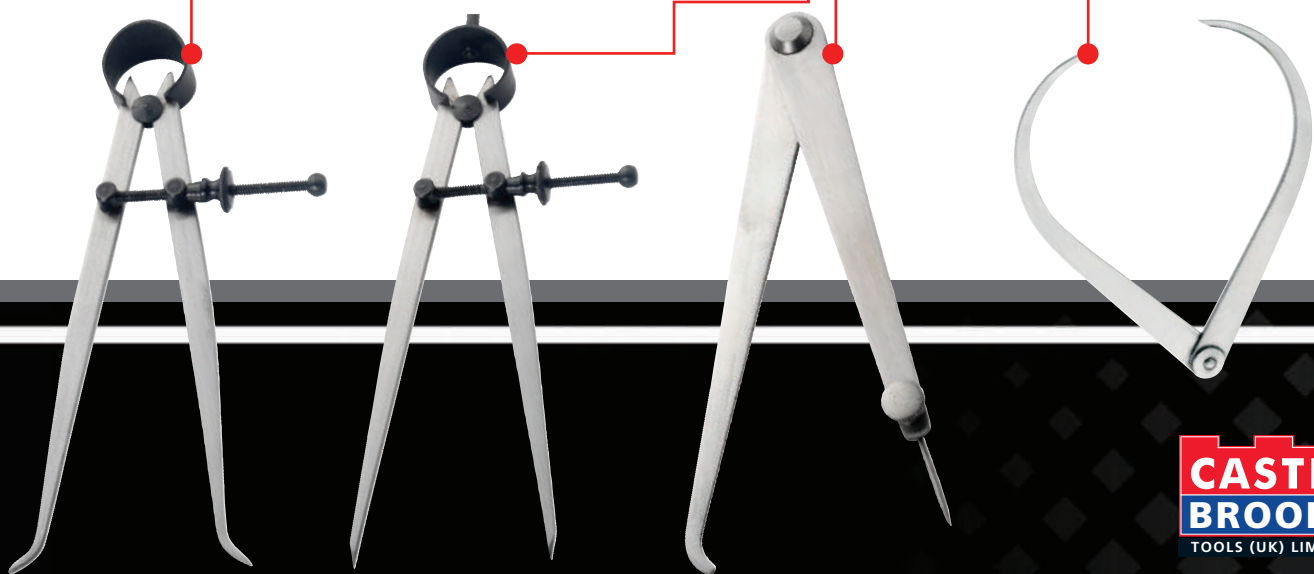
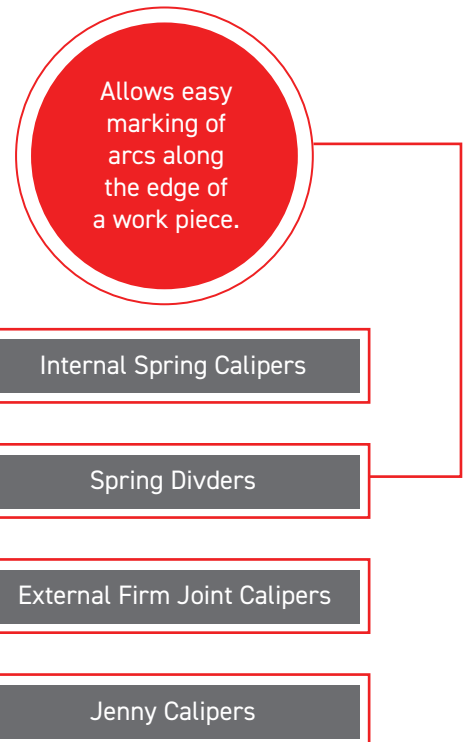

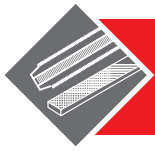

# Engineers Files & Rasps

CODE LOOSE	DESCRIPTION & SIZE	CODE HANDLED	PACK QTY	DISCOUNT GROUP
<b>FLAT FILES</b>				
C620-0004	4" Flat Bastard	C620-0004H	1	T
C620-0005	4" Flat Second	C620-0006	1	T
C620-0007	4" Flat Smooth	C620-0007H	1	T
C620-0037	6" Flat Bastard	C620-0037H	1	T
C620-0038	6" Flat Second	C620-0038H	1	T
C620-0039	6" Flat Smooth	C620-0040	1	T
C620-0088	8" Flat Bastard	C620-0089	1	T
C620-0090	8" Flat Second	C620-0091	1	T
C620-0092	8" Flat Smooth	C620-0093	1	T
C620-0153	10" Flat Bastard	C620-0154	1	T
C620-0155	10" Flat Second	C620-0156	1	T
C620-0157	10" Flat Smooth	C620-0158	1	T
C620-0203	12" Flat Bastard	C620-0204	1	T
C620-0205	12" Flat Second	C620-0205H	1	T
C620-0206	12" Flat Smooth	C620-0207	1	T
C620-0229	14" Flat Bastard	-	1	T
C620-0230	14" Flat Second	-	1	T
C620-0231	14" Flat Smooth	-	1	T
<b>HAND FILES</b>				
C620-0011	4" Hand Bastard	C620-0011H	1	T
C620-0012	4" Hand Second	C620-0012H	1	T
C620-0013	4" Hand Smooth	C620-0013H	1	T
C620-0044	6" Hand Bastard	C620-0044H	1	T
C620-0045	6" Hand Second	C620-0045H	1	T
C620-0046	6" Hand Smooth	C620-0046H	1	T
C620-0100	8" Hand Bastard	C620-0101	1	T
C620-0102	8" Hand Second	C620-0103	1	T
C620-0104	8" Hand Smooth	C620-0105	1	T
C620-0165	10" Hand Bastard	C620-0166	1	T
C620-0167	10" Hand Second	C620-0168	1	T
C620-0169	10" Hand Smooth	C620-0170	1	T
C620-0212	12" Hand Bastard	C620-0212H	1	T
C620-0213	12" Hand Second	C620-0213H	1	T
C620-0214	12" Hand Smooth	C620-0214H	1	T
C620-0235	14" Hand Bastard	-	1	T
C620-0237	14" Hand Smooth	-	1	T
<b>HALF ROUND FILES</b>				
C620-0008	4" Half Round Bastard	C620-0008H	1	T
C620-0009	4" Half Round Second	C620-0009H	1	T
C620-0010	4" Half Round Smooth	C620-0010H	1	T

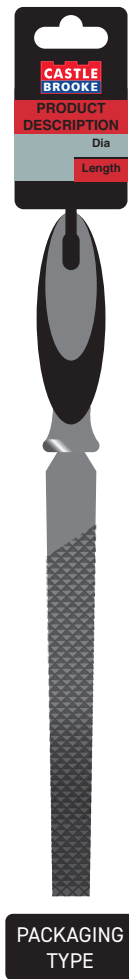
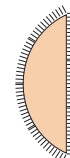

CODE LOOSE	DESCRIPTION & SIZE	CODE HANDLED	PACK QTY	DISCOUNT GROUP
C620-0041	6" Half Round Bastard	C620-0041H	1	T
C620-0042	6" Half Round Second	C620-0042H	1	T
C620-0043	6" Half Round Smooth	C620-0043H	1	T
C620-0094	8" Half Round Bastard	C620-0095	1	T
C620-0096	8" Half Round Second	C620-0097	1	T
C620-0098	8" Half Round Smooth	C620-0099	1	T
C620-0159	10" Half Round Bastard	C620-0160	1	T
C620-0161	10" Half Round Second	C620-0162	1	T
C620-0163	10" Half Round Smooth	C620-0164	1	T
C620-0208	12" Half Round Bastard	C620-0208H	1	T
C620-0209	12" Half Round Second	C620-0209H	1	T
C620-0210	12" Half Round Smooth	C620-0211	1	T
C620-0232	14" Half Round Bastard	-	1	T
C620-0233	14" Half Round Second	-	1	T
C620-0234	14" Half Round Smooth	-	1	T

#### ROUND FILES

C620-0014	4" Round Bastard	C620-0014H	1	T
C620-0015	4" Round Second	C620-0016	1	T
C620-0017	4" Round Smooth	C620-0017H	1	T
C620-0048	6" Round Bastard	C620-0048H	1	T
C620-0049	6" Round Second	C620-0049H	1	T
C620-0050	6" Round Smooth	C620-0050H	1	T
C620-0110	8" Round Bastard	C620-0111	1	T
C620-0112	8" Round Second	C620-0113	1	T
C620-0114	8" Round Smooth	C620-0115	1	T
C620-0174	10" Round Bastard	C620-0175	1	T
C620-0176	10" Round Second	C620-0177	1	T
C620-0178	10" Round Smooth	C620-0179	1	T
C620-0218	12" Round Bastard	C620-0218H	1	T
C620-0219	12" Round Second	C620-0219H	1	T
C620-0238	14" Round Bastard	-	1	T
C620-0239	14" Round Second	-	1	T

#### SQUARE FLIES

C620-0018	4" Square Bastard	C620-0018H	1	T
C620-0019	4" Square Second	C620-0019H	1	T
C620-0020	4" Square Smooth	C620-0020H	1	T
C620-0052	6" Square Bastard	C620-0052H	1	T
C620-0053	6" Square Second	C620-0053H	1	T
C620-0054	6" Square Smooth	C620-0054H	1	T
C620-0117	8" Square Bastard	C620-0118	1	T
C620-0119	8" Square Second	C620-0120	1	T



## KEY FEATURES

They can be used to smooth a range of materials - steel, non-ferrous metals, wood, plastic.

They are made from high carbon steel and heat treated so that they are tougher than the material they are to be applied to.

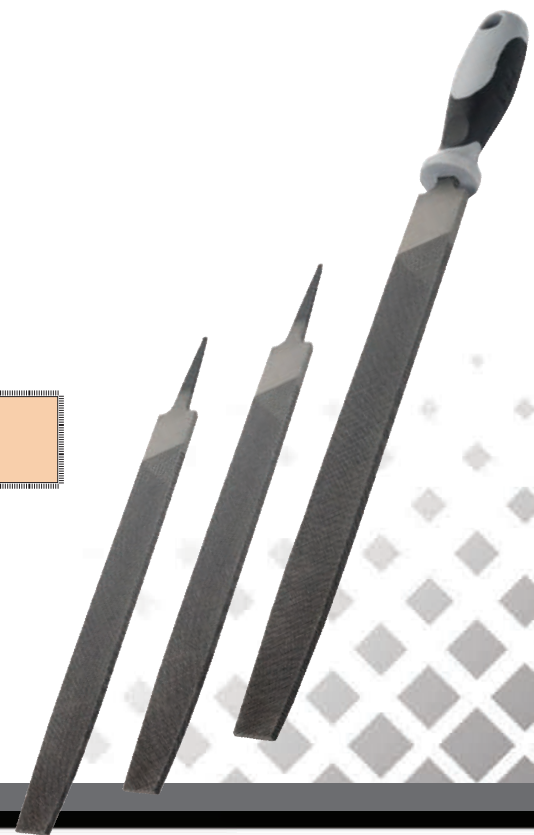
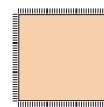
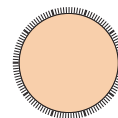

STEEL



NON-FERROUS METAL



PLASTIC



WOOD

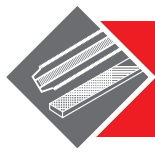

# Engineers Files & Rasps

CODE LOOSE	DESCRIPTION & SIZE	CODE HANDLED	PACK QTY	DISCOUNT GROUP
<b>SQUARE FILES</b>				
C620-0121	8" Square Smooth	C620-0122	1	T
C620-0180	10" Square Bastard	C620-0181	1	T
C620-0182	10" Square Second	C620-0183	1	T
C620-0184	10" Square Smooth	C620-0185	1	T
C620-0221	12" Square Bastard	C620-0221H	1	T
C620-0222	12" Square Second	C620-0222H	1	T
C620-0241	14" Square Bastard	-	1	T
C620-0242	14" Square Second	-	1	T
<b>3 SQUARE FILES</b>				
C620-0002	4" 3 Square Second	C620-0002H	1	T
C620-0003	4" 3 Square Smooth	C620-0003H	1	T
C620-0033	6" 3 Square Bastard	C620-0033H	1	T
C620-0034	6" 3 Square Second	C620-0034H	1	T
C620-0035	6" 3 Square Smooth	C620-0035H	1	T
C620-0081	8" 3 Square Bastard	C620-0082	1	T
C620-0083	8" 3 Square Second	C620-0084	1	T
C620-0085	8" 3 Square Smooth	C620-0086	1	T
C620-0144	10" 3 Square Bastard	C620-0145	1	T
C620-0146	10" 3 Square Second	C620-0147	1	T
C620-0148	10" 3 Square Smooth	C620-0149	1	T
C620-0200	12" 3 Square Bastard	C620-0200H	1	T
C620-0201	12" 3 Square Second	C620-0201H	1	T
C620-0202	12" 3 Square Smooth	C620-0202H	1	T
<b>WARDING FILES</b>				
C620-0021	4" Warding Bastard	-	1	T
C620-0023	4" Warding Smooth	-	1	T
C620-0055	6" Warding Bastard	-	1	T
C620-0056	6" Warding Second	-	1	T
C620-0057	6" Warding Smooth	-	1	T
C620-0123	8" Warding Bastard	-	1	T
C620-0124	8" Warding Second	-	1	T
<b>SAW FILES</b>				
C620-0024	4" Extra Slim Taper Saw File	-	1	T
C620-0047	6" Regular Taper Saw File	-	1	T
C620-0051	6" Slim Taper Saw File	-	1	T
C620-0058	6" Extra Slim Taper Saw File	-	1	T
C620-0036	6" Double Ended Saw File	-	1	T
C620-0116	8" Slim Taper Saw File	-	1	T
C620-0128	8" Extra Slim Taper File	-	1	T
C620-0087	8" Double Ended Saw File	-	1	T

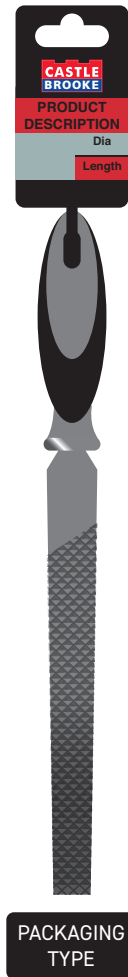
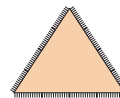
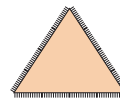
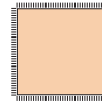

CODE LOOSE	DESCRIPTION & SIZE	CODE HANDLED	PACK QTY	DISCOUNT GROUP
C620-0108	8" Millsaw One Round	-	1	T
C620-0171	10" Millsaw One Round	C620-0172	1	T
C620-0215	12" Millsaw One Round	C620-0216	1	T
C620-0129	8" x 3/16" Chainsaw	-	1	T
C620-0130	8" x 5/32" Chainsaw	-	1	T
C620-0131	8" x 7/32" Chainsaw	-	1	T
C620-0151	10" Farmers Own	-	1	T
<b>RASPS</b>				
C620-0126	8" Wood Rasp H/Rnd	-	1	T
C620-0127	8" Wood Rasp H/Rnd	-	1	T
C620-0186	10" Wood Rasp H/Rnd	-	1	T
C620-0225	12" Wood Rasp H/Rnd	-	1	T
C620-0109	8" Regular Cabinet	-	1	T
C620-0173	10" Regular Cabinet	-	1	T
C620-0217	12" Regular Cabinet	-	1	T
<b>SPARE HANDLES</b>				
C620-0247	Grey/Black 4"	-	1	T
C620-0244	Grey/Black 6"- 8"	-	1	T
C620-0245	Grey/Black 10"-12"	-	1	T
C620-0246	Grey/Black 12"-14"	-	1	T

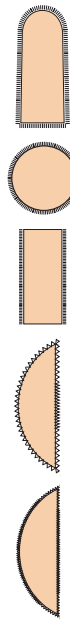

## KEY FEATURES

They can be used to smooth a range of materials - steel, non-ferrous metals, wood, plastic. They are made from high carbon steel and heat treated so that they are tougher than the material they are to be applied to.



STEEL



NON-FERROUS  
METAL



PLASTIC



WOOD

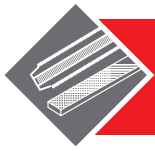

## Engineers Punches



### KEY FEATURES

High quality accurately hardened and tempered for long life and durability. The knurling is clean and well cut to provide a positive finger grip.

CODE	SIZE	PACK QTY	DISCOUNT GROUP
<b>DRIVE PIN PUNCHES 100MM(4")</b>			
C630-0001	1.5mm(1/16")	1	J
C630-0002	2.5mm(3/32")	1	J
C630-0003	3mm(1/8")	1	J
C630-0004	4mm(5/32")	1	J
C630-0010	5mm(3/16")	1	J
C630-0006	6mm(1/4")	1	J
C630-0007	8mm(5/16")	1	J
C630-0008	4pc Set-3,4,5,6mm	1	J
C630-0009	8pc Set-1.5,2.5,3,4,5,5.5,6,8mm	1	J
<b>DRIVE PIN PUNCHES 200MM(8")</b>			
C630-0011	3mm(1/8")	1	J
C630-0012	5mm(3/16")	1	J
C630-0013	6mm(1/4")	1	J
C630-0014	8mm(5/16")	1	J
C630-0015	10mm(3/8")	1	J
C630-0016	5pc Set-3,5,6,8,10mm	1	J
<b>CENTRE PUNCHES 100MM(4")</b>			
C630-0066	1.5mm(1/16")	1	J
C630-0067	2mm( 5/64")	1	J
C630-0068	2.5mm(3/32")	1	J
C630-0069	3.5mm(9/64")	1	J
C630-0070	4mm(5/32")	1	J
C630-0071	5pc Set-1.5,2,2.5,3,5,4mm	1	J
<b>AUTOMATIC CENTRE PUNCH</b>			
C630-0065	125mm	1	J

## Steel Squares

CODE	SIZE	PACK QTY	DISCOUNT GROUP
C650-0003	2"	1	J
C650-0004	3"	1	J
C650-0005	4"	1	J
C650-0006	6"	1	J
C650-0007	8"	1	J
C650-0008	9"	1	J
C650-0009	10"	1	J
C650-0010	12"	1	J

### KEY FEATURES

Made from selected steel with hardened blade, these squares have accurate right angles both on the inside and outside.

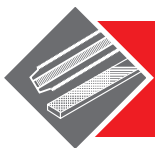
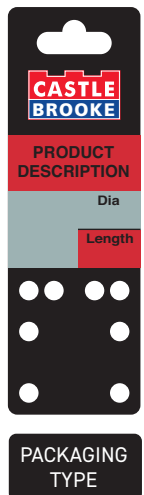

## Stainless Steel Rules

CODE	SIZE	PACK QTY	DISCOUNT GROUP
C660-0001	6" x 1/2" inch/mm	1	J
C660-0002	6" x 3/4" inch/mm	1	J
C660-0004	12" x 1.1/8" inch/mm	1	J
C660-0008	24" x 1.1/2" inch/mm	1	J
C660-0009	40" x 1.1/8" inch/mm	1	J



# Letter, Number Stamps

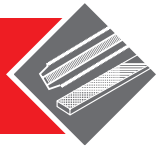

CODE	SIZE	PACK QTY	DISCOUNT GROUP
<b>LETTER STAMPS</b>			
C635-0012	1mm	1	J
C635-0013	2mm	1	J
C635-0014	3mm	1	J
C635-0015	4mm	1	J
C635-0016	5mm	1	J
C635-0017	6mm	1	J
C635-0018	8mm	1	J
C635-0019	10mm	1	J
C635-0011	12mm	1	J
<b>NUMBER STAMPS</b>			
C635-0003	1mm	1	J
C635-0004	2mm	1	J
C635-0005	3mm	1	J
C635-0006	4mm	1	J
C635-0007	5mm	1	J
C635-0008	6mm	1	J
C635-0009	8mm	1	J
C635-0010	10mm	1	J
C635-0002	12mm	1	J

## KEY FEATURES

High quality, accurately hardened and tempered for long life and durability.



◆ Packed in individual boxes.

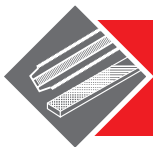

# Scribers

CODE	SIZE	PACK QTY	DISCOUNT GROUP
C660-0037	Single Ended 115mm(4.1/2")	1	J
C660-0038	Double Ended 190mm(7.1/2")	1	J
C660-0039	Single Ended 190mm(7.1/2")	1	J
C660-0040	Pocket Scriber	1	J

## KEY FEATURES

Complete line of scribes for machinists, engravers, mechanics and craftsmen. A basic tool for scribing and marking, these can be used on metal, glass, plastic and ceramics.

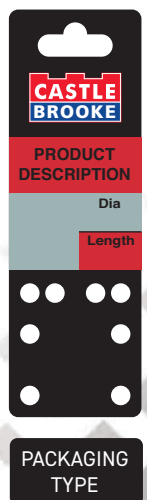
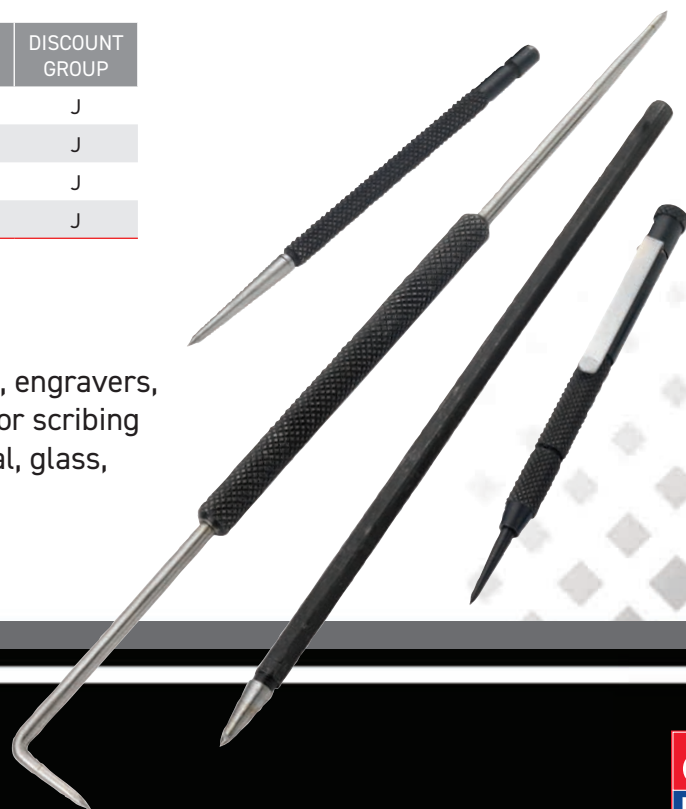

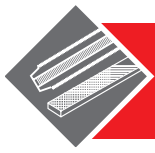

# Hex Keys & Sets

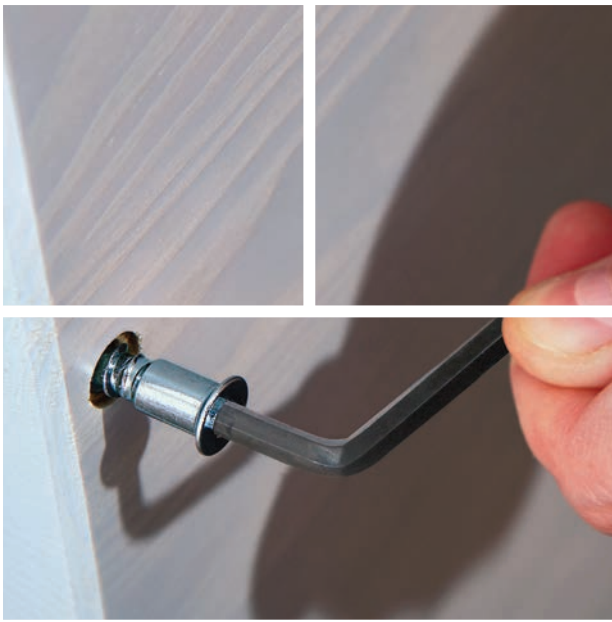

## KEY FEATURES

High quality chrome vanadium keys with high torsional strength BS 2470 Din 911

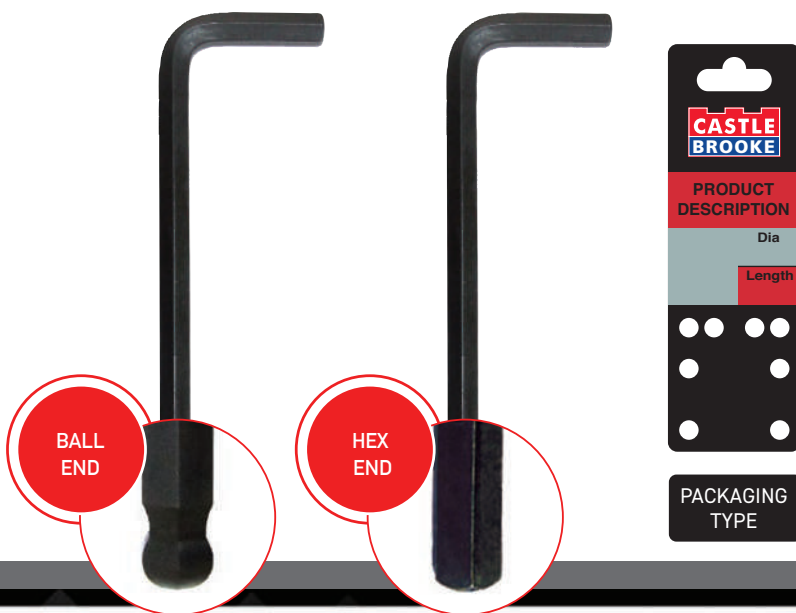

CODE	SIZE	PACK QTY	DISCOUNT GROUP
<b>SHORT ARM - 2200</b>			
C610-0101	1.0mm	1	J
C610-0102	1.5mm	1	J
C610-0103	2.0mm	1	J
C610-0104	2.5mm	1	J
C610-0105	3.0mm	1	J
C610-0106	4.0mm	1	J
C610-0107	5.0mm	1	J
C610-0108	6.0mm	1	J
C610-0109	7.0mm	1	J
C610-0110	8.0mm	1	J
C610-0111	9.0mm	1	J
C610-0117	10.0mm	1	J
C610-0118	11.0mm	1	J
C610-0119	12.0mm	1	J
C610-0120	13.0mm	1	J
C610-0121	14.0mm	1	J
C610-0122	17.0mm	1	J
C610-0123	19.0mm	1	J
C610-0124	22.0mm	1	J
C610-0125	24.0mm	1	J
C610-0126	27.0mm	1	J
C610-0131	32.0mm	1	J
<b>LONG ARM - 2400</b>			
C610-0038	1.5mm	1	J
C610-0039	2.0mm	1	J
C610-0040	2.5mm	1	J
C610-0041	3.0mm	1	J
C610-0042	4.0mm	1	J
C610-0043	5.0mm	1	J
C610-0044	6.0mm	1	J
C610-0045	7.0mm	1	J
C610-0046	8.0mm	1	J
C610-0049	10.0mm	1	J
C610-0050	12.0mm	1	J
C610-0051	14.0mm	1	J
C610-0052	17.0mm	1	J
C610-0053	19.0mm	1	J
<b>BALL END - 2311</b>			
C610-0001	1.5mm	1	J
C610-0002	2.0mm	1	J
C610-0003	2.5mm	1	J
C610-0004	3.0mm	1	J
C610-0006	4.0mm	1	J

CODE	SIZE	PACK QTY	DISCOUNT GROUP
C610-0007	5.0mm	1	J
C610-0008	6.0mm	1	J
C610-0009	7.0mm	1	J
C610-0010	8.0mm	1	J
C610-0012	10.0mm	1	J
<b>DOUBLE ENDED 'T' KEYS - 150mm LONG - 2340</b>			
C610-0029	2.0mm	1	J
C610-0030	2.5mm	1	J
C610-0031	3.0mm	1	J
C610-0032	4.0mm	1	J
C610-0033	5.0mm	1	J
C610-0034	6.0mm	1	J
C610-0035	8.0mm	1	J
C610-0036	10.0mm	1	J
<b>HEX KEY SETS</b>			
C610-0086	1.5-10mm Short Arm Easy Pack - 2246	1	J
C610-0093	1.5-10mm Long Arm Easy Pack - 2446	1	J
C610-0089	1.5-10mm Ball End Easy Pack - 2346	1	J
C610-0090	1.5-10mm Extra Long Ball Easy Pack - 2346XL	1	J
C610-0084	Pocket Knife Set Hex 2.5-10mm - 2232	1	J
C610-0087	Pocket Knife Set Ball 2.5-10mm - 2332	1	J
C610-0095	Pocket Knife Set Torx Tx9-40 - 2632	1	J



## Adjustable HSS Hand Reamers



### KEY FEATURES

Easily adjusted, they are convenient for reaming holes in metal and for repair work.



PACKAGING TYPE

CODE	DESCRIPTION & SIZE RANGE	PACK QTY	DISCOUNT GROUP
5755-0004	H1 Range 3/8-12/32" 9.52-10.32mm	1	U
5755-0005	H2 Range 13/32-7/16" 10.32-11.11mm	1	U
5755-0006	H3 Range 7/16-15/32" 11.11-11.91mm	1	U
5755-0007	H4 Range 15/32-17/32" 11.91-13.49mm	1	U
5755-0008	H5 Range 17/32-19/32" 13.49-15.08mm	1	U
5755-0009	H6 Range 19/32-21/32" 15.08-16.67mm	1	U
5755-0010	H7 Range 21/32-23/32" 16.67-18.26mm	1	U
5755-0011	H8 Range 23/32-26/32" 18.26-19.84mm	1	U
5755-0012	H9 Range 25/32-27/32" 19.84-21.43mm	1	U
5755-0013	H10 Range 27/32-15/16 " 21.43-23.81mm	1	U
5755-0014	H11 Range 15/16-1.1/16" 23.81-26.99mm	1	U
5755-0015	H12 Range 1.1/16-1.3/16" 26.99-30.16mm	1	U
5755-0016	H13 Range 1.3/16-1.11/32" 30.16-34.13mm	1	U
5755-0017	H14 Range 1.11/32-1.1/2" 34.13-38.10mm	1	U
5755-0018	H15 Range 1.1/2-1.13/16" 38.10-46.04mm	1	U
5755-0019	H16 Range 1.13/16-2.7/32" 46.04-56.36mm	1	U

For different reamer types please contact our sales team.

See page 2 for cutting oil



NON-FERROUS METAL



STEEL



# PPE RANGE

PACKED FOR RETAIL DISPLAY

## FOAM LATEX GRIP GLOVES - MICRO FOAM PALM TECHNOLOGY CONFORMS TO - EN 388:2016 2-1-2-1-X



CODE		PACK QTY	DISCOUNT GROUP
<b>SIZE 9 (L)</b>	<b>SIZE 10 (XL)</b>		
*P101-FLG09L	*P101-FLG10XL	1 PAIR	PE
P101-FLG09LTP	P101-FLG10XLTP	6 PAIR	PE
P101-FLG09LTB	P101-FLG10XLTB	120 PAIR	PE
<b>SAFETY KIT</b> P101-FLG09LSK	<b>SAFETY KIT</b> P101-FLG10XLSK	1	PE

GLOVES x 1 PAIR, FFP2 MASK x 1 (NON-VALVED), GOGGLES x 1, EAR PLUGS X 1 PAIR

\* MINIMUM ORDER QTY IN UNITS OF 6 PAIRS



SINGLE PACK 1

## FOAM LATEX WATERPROOF GRIP GLOVES CONFORMS TO - EN 388:2016 2-1-3-1-X



NEW

CODE		PACK QTY	DISCOUNT GROUP
<b>SIZE 9 (L)</b>	<b>SIZE 10 (XL)</b>		
*P101-FLWG09L	*P101-FLWG10XL	1 PAIR	PE
P101-FLWG09LTP	P101-FLWG10XLTP	6 PAIR	PE
P101-FLWG09LTB	P101-FLWG10XLTB	120 PAIR	PE
<b>SAFETY KIT</b> P101-FLWG09LSK	<b>SAFETY KIT</b> P101-FLWG10XLSK	1	PE

GLOVES x 1 PAIR, FFP2 MASK x 1 (NON-VALVED), GOGGLES x 1, EAR PLUGS X 1 PAIR

\* MINIMUM ORDER QTY IN UNITS OF 6 PAIR



TRADE PACK 6

## NITRILE FOAM GRIP GLOVES - MICRO FOAM PALM TECHNOLOGY CONFORMS TO - EN 388:2016 4-1-2-1-X



CODE		PACK QTY	DISCOUNT GROUP
<b>SIZE 9 (L)</b>	<b>SIZE 10 (XL)</b>		
*P101-NFG09L	*P101-NFG10XL	1 PAIR	PE
P101-NFG09LTP	P101-NFG10XLTP	6 PAIR	PE
P101-NFG09LTB	P101-NFG10XLTB	120 PAIR	PE
<b>SAFETY KIT</b> P101-NFG09LSK	<b>SAFETY KIT</b> P101-NFG10XLSK	1	PE

GLOVES x 1 PAIR, FFP2 MASK x 1 (NON-VALVED), GOGGLES x 1, EAR PLUGS X 1 PAIR

\* MINIMUM ORDER QTY IN UNITS OF 6 PAIRS



BULK PACK 120

## PU GRIP GLOVES CONFORMS TO - EN 388:2016 4-1-2-1-X



CODE		PACK QTY	DISCOUNT GROUP
<b>SIZE 9 (L)</b>	<b>SIZE 10 (XL)</b>		
*P101-PUG09L	*P101-PUG10XL	1 PAIR	PE
P101-PUG09LTP	P101-PUG10XLTP	6 PAIR	PE
P101-PUG09LTB	P101-PUG10XLTB	120 PAIR	PE
<b>SAFETY KIT</b> P101-PUG09LSK	<b>SAFETY KIT</b> P101-PUG10XLSK	1	PE

GLOVES x 1 PAIR, FFP2 MASK x 1 (NON-VALVED), GOGGLES x 1, EAR PLUGS X 1 PAIR

\* MINIMUM ORDER QTY IN UNITS OF 6 PAIR



SAFETY KIT 1



DISPOSABLE EAR PLUGS  
EN352-2002

## THERMAL GRIP GLOVES - MICRO FOAM PALM TECHNOLOGY CONFORMS TO - EN 388:2003 2-2-4-2



CODE		PACK QTY	DISCOUNT GROUP
<b>SIZE 10 (XL)</b>			
*P101-THG10XL		1 PAIR	PE
P101-THG10XLTP		6 PAIR	PE
P101-THG10XLTB		120 PAIR	PE

\* MINIMUM ORDER QTY IN UNITS OF 6 PAIRS

CODE	PACK QTY	DISC GROUP
P104-EP01	200 PAIRS	PE



FACE SHIELD EN166 1.B VISOR & BROWGUARD UNIT		
CODE	PACK QTY	DISCOUNT GROUP
P103-FS01	1 (Complete unit)	PE
P103-FSSV01	1 (spare visor)	PE



CLEAR LENS SAFETY GOGGLES DIRECT VENTED EN166:2001 1.B		
CODE	PACK QTY	DISCOUNT GROUP
P103-SG01	1	PE



PREMIUM SAFETY GOGGLES INDIRECT VENTED EN166:2001 1.B		
CODE	PACK QTY	DISCOUNT GROUP
P103-SG02	1	PE



SAFETY GLASSES EN166: 2001 1.F			
CODE	LENS TYPE	PACK QTY	DISCOUNT GROUP
P103-SGL01	CLEAR	1	PE
P103-SGLS02	SMOKE	1	PE
P103-SGLY03	YELLOW	1	PE

EAR DEFENDERS LIGHTWEIGHT ADJUSTABLE HEADBAND EN352-1:2002 27dB		
CODE	PACK QTY	DISCOUNT GROUP
P104-ED01	1	PE



TWIN PACK **2**    5 x TWIN PACK **10**

TWIN PACK **2**    5 x TWIN PACK **10**

FFP3V MOULDED CUP MASKS PLUS VALVE		
CODE	PACK QTY	DISCOUNT GROUP
P102-FFP3V2P	2	PE
P102-FFP3VB	10 (2 x 5)	PE

FFP2V MOULDED CUP MASKS PLUS VALVE		
CODE	PACK QTY	DISCOUNT GROUP
P102-FFP2V2P	2	PE
P102-FFP2VB	10 (2 x 5)	PE

HI-VIS VEST CLASS 2 EN471			
CODE	PACK QTY	DISCOUNT GROUP	
SIZE M	SIZE L		
P105-HIVIS2M	P105-HIVIS2L	1	PE
SIZE XL	SIZE XXL		
P105-HIVIS2XL	P105-HIVIS2XXL	1	PE



HELMET EN397 - LIGHTWEIGHT			
CODE	PACK QTY	DISCOUNT GROUP	
WHITE	BLUE	YELLOW	
P106-HW	P106-HB	P106-HY	1 PE



ALL HI-VIS CLOTHING IS ALSO AVAILABLE IN ORANGE PLEASE CONTACT US

HI-VIS BOMBER JACKET			
CODE	PACK QTY	SIZE	DISCOUNT GROUP
P107-HIVISYBJM	1	M	PE
P107-HIVISYBJL	1	L	PE
P107-HIVISYBJXL	1	XL	PE
P107-HIVISYBJXXL	1	XXL	PE

HI-VIS PARKA JACKET			
CODE	PACK QTY	SIZE	DISCOUNT GROUP
P107-HIVISYPJM	1	M	PE
P107-HIVISYPJL	1	L	PE
P107-HIVISYPJXL	1	XL	PE
P107-HIVISYPJXXL	1	XXL	PE



CODE	DESCRIPTION	PACK QTY
C900-0017	Masonry Drills 130 Pcs	1
<b>3 TIER RACK CONTENTS</b>		
C210-055100	- 5.5x100mm x 10	
C210-060100	- 6.0x100mm x 10	
C210-070100	- 7.0x100mm x 10	
C210-080120	- 8.0x120mm x 10	
C210-100120	- 10.0x120mm x 10	
C210-120150	- 12.0x150mm x 10	
C210-080200	- 8.0x200mm x 6	
C210-100200	- 10.0x200mm x 6	
C210-120200	- 12.0x200mm x 6	
C210-140200	- 14.0x200mm x 6	
C210-160200	- 16.0x200mm x 6	
C210-200200	- 20.0x200mm x 6	
C210-070300	- 7.0x300mm x 5	
C210-080300	- 8.0x300mm x 5	
C210-100300	- 10.0x300mm x 5	
C210-120300	- 12.0x300mm x 5	
C210-200300	- 20.0x300mm x 5	
C210-250300	- 25.0x300mm x 5	
C210-199997SET	- 5 Pcs 5.0/6.0/7.0/8.0/10.0mm x 4	

CODE	DESCRIPTION	PACK QTY
C900-0027	HSS-Co5 Jobber Drills 135° Split Point 190 Pcs	1
<b>3 TIER RACK CONTENTS</b>		
C107-0015W	- 1.5mm x 10	
C107-0020W	- 2.0mm x 10	
C107-0025W	- 2.5mm x 10	
C107-0030W	- 3.0mm x 10	
C107-0032W	- 3.2mm x 10	
C107-0035W	- 3.5mm x 10	
C107-0040W	- 4.0mm x 10	
C107-0042W	- 4.2mm x 10	
C107-0045W	- 4.5mm x 10	
C107-0050W	- 5.0mm x 10	
C107-0055W	- 5.5mm x 10	
C107-0060W	- 6.0mm x 10	
C107-0065W	- 6.5mm x 10	
C107-0068W	- 6.8mm x 10	
C107-0070W	- 7.0mm x 5	
C107-0075W	- 7.5mm x 5	
C107-0080W	- 8.0mm x 5	
C107-0085W	- 8.5mm x 5	
C107-0090W	- 9.0mm x 5	
C107-0095W	- 9.5mm x 5	
C107-0100W	- 10.0mm x 5	
C107-0110W	- 11.0mm x 5	
C107-0120W	- 12.0mm x 5	
C107-0130W	- 13.0mm x 5	

CODE	DESCRIPTION	PACK QTY
C900-0016	HSS Jobber Drills 135° Split Point 225 Pcs	1
<b>3 TIER RACK CONTENTS</b>		
C101-0015W	- 1.5mm x 10	
C101-0020W	- 2.0mm x 10	
C101-0025W	- 2.5mm x 10	
C101-0030W	- 3.0mm x 10	
C101-0032W	- 3.2mm x 10	
C101-0035W	- 3.5mm x 10	
C101-0040W	- 4.0mm x 10	
C101-0042W	- 4.2mm x 10	
C101-0045W	- 4.5mm x 10	
C101-0050W	- 5.0mm x 10	
C101-0055W	- 5.5mm x 10	
C101-0060W	- 6.0mm x 10	
C101-0065W	- 6.5mm x 10	
C101-0068W	- 6.8mm x 10	
C101-0070W	- 7.0mm x 10	
C101-0075W	- 7.5mm x 10	
C101-0080W	- 8.0mm x 10	
C101-0085W	- 8.5mm x 10	
C101-0090W	- 9.0mm x 10	
C101-0095W	- 9.5mm x 10	
C101-0100W	- 10.0mm x 10	
C101-0110W	- 11.0mm x 5	
C101-0120W	- 12.0mm x 5	
C101-0130W	- 13.0mm x 5	

CODE	DESCRIPTION	PACK QTY
C900-0019	SDS Plus Drills 94 Pcs	1
<b>3 TIER RACK CONTENTS</b>		
C230-055110	- 5.5x110mm x 3	
C230-060110	- 6.0x110mm x 3	
C230-055160	- 5.5x160mm x 6	
C230-060160	- 6.0x160mm x 6	
C230-070160	- 7.0x160mm x 6	
C230-080160	- 8.0x160mm x 6	
C230-100160	- 10.0x160mm x 6	
C230-070210	- 7.0x210mm x 5	
C230-080210	- 8.0x210mm x 5	
C230-100210	- 10.0x210mm x 5	
C230-120210	- 12.0x210mm x 5	
C230-140210	- 14.0x210mm x 5	
C230-160210	- 16.0x210mm x 4	
C230-200210	- 20.0x210mm x 4	
C230-080460	- 8.0x460mm x 4	
C230-100460	- 10.0x460mm x 4	
C230-120450	- 12.0x450mm x 4	
C230-140450	- 14.0x450mm x 4	
C230-160450	- 16.0x450mm x 3	
C230-200450	- 20.0x450mm x 3	
C230-250450	- 25.0x450mm x 3	

**RETAIL  
DISPLAY**



CODE	DESCRIPTION	PACK QTY
C900-0028	Holesaws 53 Pcs	1
<b>3 TIER RACK CONTENTS</b>		
C410-0160	- 16.0mm x 4	
C410-0190	- 19.0mm x 4	
C410-0220	- 22.0mm x 4	
C410-0250	- 25.0mm x 4	
C410-0290	- 29.0mm x 4	
C410-0320	- 32.0mm x 3	
C410-0380	- 38.0mm x 3	
C410-0440	- 44.0mm x 3	
C410-0510	- 51.0mm x 2	
C410-0570	- 57.0mm x 2	
C410-0600	- 60.0mm x 2	
C410-0640	- 64.0mm x 2	
C410-0760	- 76.0mm x 2	
C410-0860	- 86.0mm x 2	
C410-1020	- 102.0mm x 1	
C410-1520	- 152.0mm x 1	
C410-90011	- A1 Arbor x 6	
C410-90012	- A2 Arbor x 4	

CODE	DESCRIPTION	PACK QTY
C900-0018	Wood Drills 106 Pcs	1
<b>3 TIER RACK CONTENTS</b>		
<b>AUGER BITS</b>		
C310-100230	- 10.0x230mm x 4	
C310-120230	- 12.0x230mm x 4	
C310-160230	- 16.0x230mm x 4	
C310-200230	- 20.0x230mm x 3	
C310-220230	- 22.0x230mm x 3	
C310-250230	- 25.0x230mm x 2	
C310-320230	- 32.0x230mm x 2	
<b>TRIPLE POINTED FLAT BITS</b>		
C330-0120	- 12.0mm x 10	
C330-0160	- 16.0mm x 10	
C330-0200	- 20.0mm x 10	
C330-0220	- 22.0mm x 10	
C330-0250	- 25.0mm x 10	
C330-0320	- 32.0mm x 10	
C330-1998SET	- 6 Pcs Flat Bit Set 10/13/16/19/22/25.0mm x 4	
C335-0002	- Extension Rod 300mm x 5	
<b>TRIPLE FLUTED WOOD DRILLS</b>		
C350-0160	- 16.0x165mm x 3	
C350-0200	- 20.0x165mm x 3	
C350-0220	- 22.0x165mm x 3	
C350-0250	- 25.0x165mm x 3	
C350-0320	- 32.0x165mm x 3	

CODE	DESCRIPTION	PACK QTY
C900-0021	Jigsaw & Reciprocating Saw Blades 75Pcs	1
<b>3 TIER RACK CONTENTS</b>		
<b>JIGSAW BLADES</b>		
C440-0017	- 75mm O/L 21TPI HSS Metal T118A HSS x 5	
C440-0020	- 75mm O/L 12TPI HSS Metal T118B x 5	
C440-0023	- 100mm O/L 8TPI HCS Wood T111C x 5	
C440-0026	- 100mm O/L 10TPI HCS Wood T101B x 5	
C440-0040	- 152mm O/L 6TPI HCS Wood T344D x 5	
<b>RECIPROCATING SAW BLADES</b>		
C445-0001	- 150x19x0.9mm 18TPI Bi-Metal Metal S922EF x 5	
C445-0002	- 225x19x0.9mm 18TPI Bi-Metal Metal S1122EF x 5	
C445-0003	- 225x19x0.9mm 14TPI Bi-Metal Metal S1122BF x 5	
C445-0004	- 150x19x0.9mm 10/14TPI Bi-Metal Wood/MTL S922VF x 5	
C445-0005	- 200x19x0.9mm 10TPI Bi-Metal Wood/MTL S1022HF x 5	
C445-0006	- 225x19x0.9mm 10/14TPI Bi-Metal Wood/MTL S1122VF x 5	
C445-0007	- 150x19x1.25mm 6TPI HCS Wood S644D x 5	
C445-0008	- 200x19x1.25mm 6/10TPI HCS Wood S2345X x 5	
C445-0009	- 240x19x1.50mm 5TPI HCS GN Wood S1531L x 5	
C445-0010	- 300x19x1.25mm 6TPI HCS Wood S1344D x 5	

All hanging pegs are removable enabling you to have small or larger spacing between each product, giving you more versatility to display different types of products.

Other combinations can be tailored to suit your requirements just ask one of our sales team.

Contact us for prices.  
**+44 (0)114 261 7200**  
[info@castlebrooke.co.uk](mailto:info@castlebrooke.co.uk)

CODE	DESCRIPTION	PACK QTY
<b>HSS JOBBER DRILLS - GROUND FLUTE, SPLIT POINT. DIN 338 148Pcs</b>		
C109-9995 STARTER SET	5 of each 1.0 - 10.0mm x 0.5mm Incl. 3.2, 4.2, 4.8, 6.8 Except 10 of each 3.0, 5.0, 6.0 mm 3 of each 10.5-13.0 mm x 0.5mm	1
<b>TIN COATED HSS JOBBER DRILLS - GROUND FLUTE, SPLIT POINT. DIN 338 148Pcs</b>		
C109-9993 STARTER SET	5 of each 1.0 - 10.0mm x 0.5mm Incl. 3.2, 4.2, 4.8, 6.8 Except 10 of each 3.0, 5.0, 6.0 mm 3 of each 10.5-13.0 mm x 0.5mm	1
<b>HSS-Co5 JOBBER DRILLS - GROUND FLUTE, SPLIT POINT. DIN 338 148Pcs</b>		
C109-9994 STARTER SET	5 of each 1.0 - 10.0mm x 0.5mm Incl. 3.2, 4.2, 4.8, 6.8 Except 10 of each 3.0, 5.0, 6.0 mm 3 of each 10.5-13.0 mm x 0.5mm	1

CODE	DESCRIPTION	PACK QTY
<b>HSS JOBBER DRILLS - GROUND FLUTE, SPLIT POINT. DIN 338 260 Pcs</b>		
C109-9998 FULL SET	10 of each 1.0 - 10.0mm x 0.5mm Incl. 3.2, 4.2, 4.8, 6.8 5 of each 10.5-13.0 mm x 0.5mm	1
<b>TIN COATED HSS JOBBER DRILLS - GROUND FLUTE, SPLIT POINT. DIN 338 260 Pcs</b>		
C109-9997 FULL SET	10 of each 1.0 - 10.0mm x 0.5mm Incl. 3.2, 4.2, 4.8, 6.8 5 of each 10.5-13.0 mm x 0.5mm	1
<b>HSS-Co5 JOBBER DRILLS - GROUND FLUTE, SPLIT POINT. DIN 338 260 Pcs</b>		
C109-9996 FULL SET	10 of each 1.0 - 10.0mm x 0.5mm Incl. 3.2, 4.2, 4.8, 6.8 5 of each 10.5-13.0 mm x 0.5mm	1

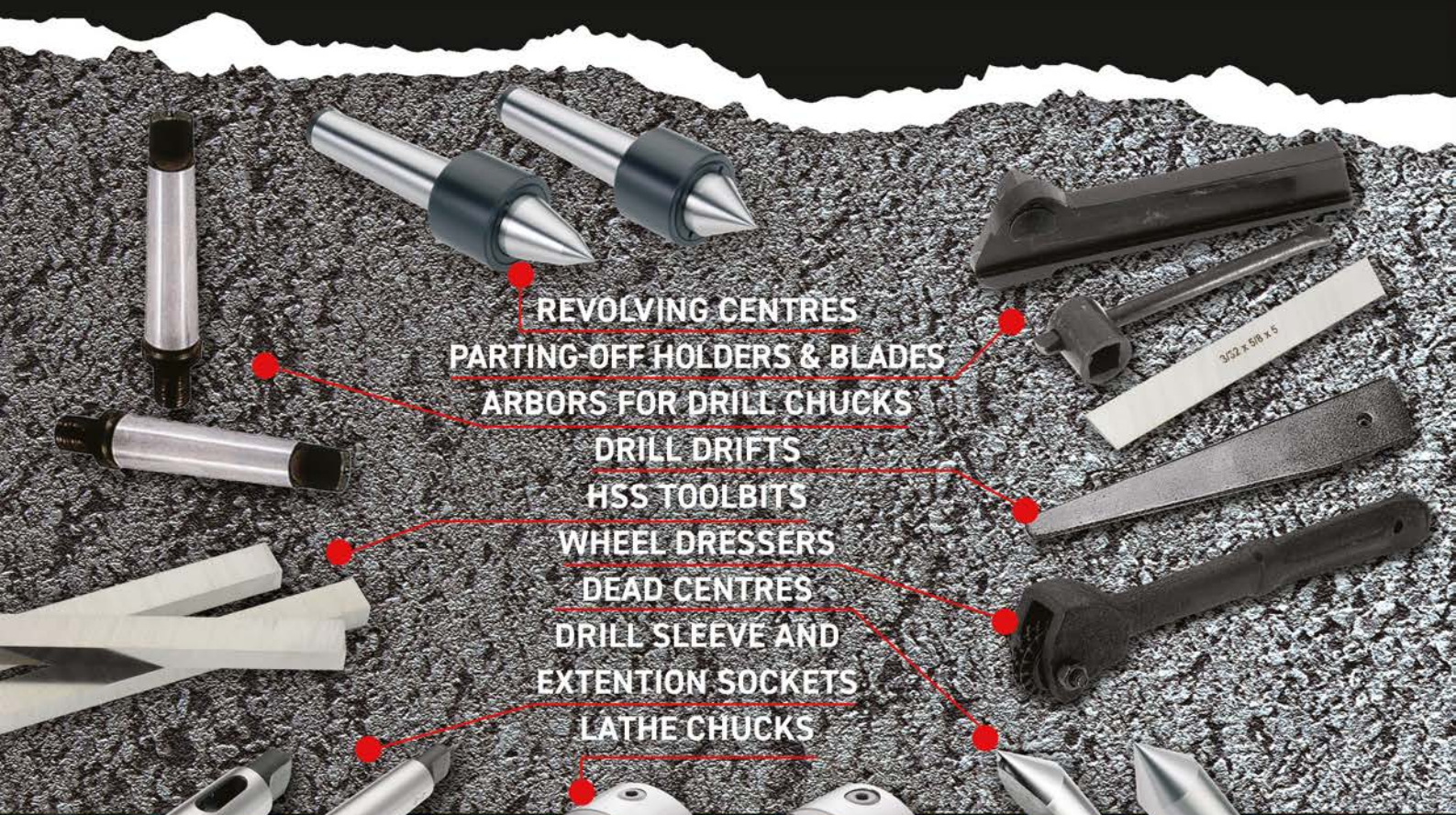

**REVOLVING CENTRES**  
**PARTING-OFF HOLDERS & BLADES**  
**ARBORS FOR DRILL CHUCKS**  
**DRILL DRIFTS**  
**HSS TOOLBITS**  
**WHEEL DRESSERS**  
**DEAD CENTRES**  
**DRILL SLEEVE AND EXTENTION SOCKETS**  
**LATHE CHUCKS**

**Can't find what you're looking for?**

Please contact Castle Brooke Tools with your requirements and for more details on additional product ranges.

+44 (0)114 261 7200

info@castlebrooke.co.uk

www.castlebrooke.co.uk



# TERM AND CONDITIONS

## CONDITIONS FOR THE SUPPLY OF GOODS BY CASTLE BROOKE TOOLS (UK) LIMITED

### 1 CONTRACT TERMS, VARIATIONS AND REPRESENTATIONS

(a) In these conditions, "the Seller" means Castle Brooke Tools (UK) Limited may sell the Goods; "the Buyer" means the individual, firm, company or other party with whom the Seller contracts; "the Goods" means the Goods (including any instalment of the Goods) which the Seller is to supply in accordance with these conditions; "the Services" means the whole or any part of the services which the Seller is to supply or carry out; "the Contract" means any contract under which the Seller provides Services and/or sells the Goods to the Buyer; "Supply" includes (but is not limited to) any supply under a contract of sale and "International Supply Contract" means such a contract as is described in section 26 (3) of the Unfair Contract Terms Act 1977.

(b) No order in pursuance of any quotation or otherwise shall be binding on the Seller unless and until such order is accepted by the Seller. Any Contract made between the Seller and the Buyer shall be subject to these conditions and save as after mentioned no representative or agent of the Seller has authority to agree any terms or make any representations inconsistent with them or to enter into any contract except on the basis of them; any such term representation or contract will bind the Seller only if in writing and signed by an authorised signatory of the Seller.

(c) Unless otherwise agreed in writing by the Seller these conditions shall apply to the exclusion of any terms and conditions stipulated or referred to by the Buyer in his order or pre-contract negotiations or any inconsistent terms implied by law or trade custom, practice or course of dealing.

(d) Any general description contained in the Seller's catalogues or other advertising material shall not form a representation or be part of the Contract.

(e) Where the Seller has not given a written acknowledgment of the Buyer's order these conditions will nonetheless apply to the Contract provided that the Buyer has had prior notice of them.

(f) The Seller reserves the right to correct any clerical or typographical errors made by its employees at any time.

### 2 SPECIFICATION, INSTRUCTIONS OR DESIGN

(a) The Buyer shall be responsible to the Seller for ensuring the accuracy of the terms of any order (including any applicable specification) submitted by the Buyer, and for giving the Seller any necessary information relating to the Goods or Services within a sufficient time to enable the Seller to perform the Contract in accordance with its terms.

(b) If the Goods are made to a specification, instruction or design supplied by the Buyer or any third party on behalf of the Buyer then (i) the suitability and accuracy of that specification, instruction or design will be the Buyer's responsibility; (ii) the Buyer will indemnify the Seller against any infringement or alleged infringement of any third party's intellectual property rights including but not limited to patent, design right, registered design, trademark, trade name or copyright and any loss, damage or expense which it may incur by reason of any such infringement or alleged infringement in any country; (iii) the Buyer will indemnify the Seller against any loss, damage or expense in respect of any liability arising in any country by reason of the Goods being made to such specification, instruction or design.

### 3 QUOTATIONS AND PRICES

(a) The Seller shall be entitled to increase its prices at anytime to take account of any increase in the cost to the Seller of purchasing any goods or materials or manufacturing working on or supplying any goods (including but not limited to any such increase arising from any error or inadequacy in any specification, instructions or design provided by the Buyer, any modification carried out by the Seller at the Buyer's request or any change in exchange rates) and such increased prices ruling at the date of dispatch by the Seller shall be substituted for the previous Contract price.

(b) All prices quoted are exclusive of any applicable value added tax and the Buyer shall pay any and all taxes duties and other government charges payable in respect of the Goods and/or Services.

(c) All prices shown are in British Pounds (Pound Sterling/GBP) unless otherwise stated.

### 4 DELIVERY

(a) Unless otherwise agreed in writing by the Seller, the Seller shall deliver the Goods by the means most convenient to the Seller to the address or addresses specified by the Buyer at the time of placing his order or (in the event that the Buyer fails so to specify an address) to any address at which the Buyer resides or carries on business. The Seller shall be entitled to add to the contract price a reasonable charge for packaging and delivery. Off-loading shall be at the Buyer's expense.

(b) If the Contract requires the Buyer to take delivery of the Goods at the Seller's premises the Seller shall notify the Buyer of the collection date (being the date on which the Goods are or will be ready for delivery) and the Buyer shall take delivery of the Goods within 7 days of the collection date. Loading of the Goods shall be at the Buyer's expense.

(c) Should the Seller be delayed in or prevented from making delivery of the Goods or carrying out the Services due to any cause whatsoever beyond the reasonable control of the Seller the Seller shall be at liberty to terminate the Contract or suspend the order placed by the Buyer without incurring any liability for any loss or damage arising therefrom, but without prejudice in any such case to rights accrued to the Seller in respect of deliveries already made.

(d) While the Seller will endeavour to deliver the Goods or complete the Services by any date or within any period agreed upon, such dates and periods are estimates only given in good faith and the Seller will not be liable for any failure to deliver the Goods or carry out the Services by such a date or within such a period. Time for delivery shall not be of the essence of the Contract. Moreover, the Seller shall be entitled to defer delivery until any monies due from the Buyer have been received.

(e) Where the Goods are to be delivered in instalments, each delivery shall constitute a separate contract and failure by the Seller to deliver any one or more of the instalments in accordance with these conditions or any claim by the Buyer in respect of any one or more instalment shall not entitle the Buyer to treat the Contract as a whole as repudiated.

(f) If the Buyer fails to take delivery of the Goods or fails to give the Seller adequate delivery instructions at the time stated for delivery (otherwise than by reason of any cause beyond the Buyer's reasonable control or by reason of the Seller's fault) then, without prejudice to any other right or remedy available to the Seller, the Seller may at its option; (i) store the Goods until actual delivery and charge the Buyer for the reasonable costs (including insurance) of storage or; (ii) sell the Goods at the best price readily obtainable and (after deducting all reasonable storage and selling expenses) account to the Buyer for the excess over the price under the Contract or charge the Buyer for any shortfall below the price under the Contract. The Buyer shall pay such shortfall to the Seller within 28 days of the date of the Seller's demand therefor.

### 5 RISK IN THE GOODS

(a) Save in the case of International Supply Contracts and subject to any agreement in writing by the Seller, the risk in Goods which the Seller agrees to supply shall pass to the Buyer on (i) delivery or (ii) the date on which, the Goods being ready for delivery, delivery is postponed at the Buyer's request, whichever shall first occur. Delivery shall be deemed to be completed before off-loading or (in the case of delivery at the Seller's premises) loading of the Goods.

(b) All other goods shall be at the Buyer's sole risk at all times, and the Seller shall not be liable for any loss of or damage sustained by any goods left with the Seller howsoever caused and whether or not attributable to negligence on the part of the Seller or negligence or wilful default on the part of any servant or agent of the Seller.

### 6 PAYMENT

(a) Unless otherwise specified in writing by the Seller payment of the Seller's invoices shall be made by the Buyer net cash not later than 30 days after the agreed for the Services shall be made not later than 30 days after the date of which such Services are completed or, in the event that the Services cannot be carried out due to the act or default of the Buyer, its servants or agents, when the Seller is ready to carry out the Services. Time for payment shall be of the essence of the Contract. If payment is not made with this condition all monies owed by the buyer to the seller shall immediately become due and payable and recoverable forthwith. Without prejudice to any other rights of the Seller interest will be payable on all overdue accounts at National Westminster Bank Plc base rate plus 4% and for the purposes of clauses 7 and 9 hereof the full purchase price of the Goods or the Services shall include all interest payable hereunder.

### 7 FAILURE TO PAY, CANCELLATION OR DEFERMENT

(a) For the purposes of this clause "an intervening event" shall mean any such event as is described in sub-clause (c) hereof.

(b) If there shall be an intervening event the Seller may, within a reasonable time thereafter, defer or cancel any further deliveries or services, stop any Goods in transit and treat the Contract of which these conditions form part as determined but without prejudice to its rights to the full purchase price for Goods delivered and Services performed and damages for any loss suffered in consequence of such determination.

(c) An intervening event shall be any of the following: (i) failure by the Buyer to make any payment when it becomes due; (ii) breach by the Buyer of any of the terms or conditions of the Contract; (iii) the Buyer's proposal for or entry into any composition or arrangement with creditors; (iv) the presentation against the Buyer of any Petition for a Bankruptcy Order, Administration Order, Winding-Up Order, or similar process; (v) the appointment of an Administrative Receiver or Receiver in respect of the business or any part of the assets of the Buyer; (vi) the Seller forming the reasonable opinion that the Buyer has become or is likely in the immediate future to be-come unable to pay his, her or its debts (adopting, in the case of a Company, the definition of that term set out in Section 123 of the Insolvency Act 1986).

(d) Cancellation by the Buyer will only be accepted at the discretion of the Seller and in any case on condition that any costs or expenses incurred by the Seller up to the date of cancellation and all loss or damage resulting to the Seller by reason of such cancellation will be paid by the Buyer to the Seller forthwith. Acceptance of such cancellation will only be binding on the Seller if in writing and signed by an authorised signatory of the Seller.

(e) Any costs incurred by the Seller due to suspension or deferment of any order by the Buyer or in the event that the Buyer defaults in collecting, or giving instructions for the delivery of, any Goods will be payable by the Buyer forthwith on demand.

### 8 LIMITATION OF LIABILITY

(a) The Seller will have no liability for damage in transit, shortage of delivery or loss of Goods unless the Buyer shall have given to the Seller written notice of such damage, shortage or loss with reasonable particulars thereof within 48 hours of receipt of the Goods or (in the case of total loss) of receipt of the invoice or other notification of dispatch. The Seller's liability, if any, shall be limited to replacing or (in its discretion) repairing such Goods and it shall be a condition precedent to any such liability that the Buyer shall if so requested provide authority for the Seller's servants or agents to inspect any damaged Goods within 14 days of such request.

(b) The Seller will have no liability for any consequential loss arising out of any damage in transit shortage of delivery or loss of Goods.

(c) Save as otherwise provided in these conditions the Seller's liability in respect of any defect in or failure of Goods whether the Supplier's own branded Goods or third party Goods procured and supplied by the Supplier to the Buyer is limited to replacing or (in its discretion) repairing or paying for the repair or replacement of such Goods

(d) All Goods sold by the Seller are supplied with the benefit of the terms implied by section 12 of the Sale of Goods Act 1979. Subject thereto, and whether or not the Contract is a contract of sale, all other conditions, warranties and other terms express or implied, statutory or otherwise, are expressly excluded, save insofar as contained herein or as otherwise expressly agreed by the Seller in writing PROVIDED that if and insofar as any legislation or any order made thereunder shall make or have made it unlawful to exclude or purport to exclude from the Contract any term or shall have made unenforceable any attempt to exclude any such term, the foregoing provisions of this paragraph will not apply to any such term.

(e) Nothing in these conditions shall exclude or restrict any liability that the Seller may have by virtue of the Consumer Protection Act 1987.

(f) Subject to the foregoing and to the provisions of section 2(i) of the Unfair Contracts Terms Act 1977 the Seller shall have no liability to the Buyer in the event of any negligence or wilful default on the part of its servants or agents in or in connection with the supply of any Goods or the design or manufacture thereof or in the carrying out of any Services.

### 9 RETENTION OF TITLE

(a) The following provisions shall apply to all contracts other than International Supply Contracts and to all Goods which under the Contract the Seller agrees to supply to the Buyer. No failure by the Seller to enforce strict compliance by the Buyer with such provisions shall constitute a waiver thereof and no termination of the Contract shall prejudice limit or extinguish the Seller's rights under this paragraph. (i) Upon delivery of the Goods the Buyer shall hold the Goods solely as bailee for the Seller and the Goods shall remain the property of the Seller until such time as the Buyer shall have paid to the Seller and the Seller shall have cleared funds for the full purchase price thereof. Until such time the Seller shall be entitled to recover the Goods or any part thereof and for the purpose of exercising such rights the Buyer hereby grants a licence to the Seller its employees and agents with appropriate transport to enter upon the Buyer's premises and any other location where the Goods are situated and remove the Goods. (ii) The Buyer is hereby granted a licence by the Seller to incorporate the Goods in any other products. (iii) The licence granted under sub-clause (i) hereof shall extend to detaching the Goods from any property to which they are attached or into which they have been incorporated or from any other products or Goods to which they have been attached pursuant to the licence granted under sub-clause (ii) hereof. (iv) The Buyer is hereby licensed to agree to sell on the Goods and any products incorporating any of them on condition that the Buyer shall inform its customer of the provisions of sub-clauses (i)-(iii) hereof. The Buyer acts as the Seller's bailee in respect of any such sale and shall, immediately upon receipt of the proceeds of sale, and whether or not payment has become due under clause 6 hereof, remit to the Seller the full purchase price of the Goods sold on less any part thereof which has already been paid and until such amount has been so remitted shall hold such amount as trustee and agent for the Seller. (v) The Buyer shall maintain all appropriate insurance in respect of the Goods from the date or dates on which the risk therein passes to him. In the event of any loss or damage occurring while the Goods remain the property of the Seller the Buyer shall immediately on receipt of the insurance monies, remit to the Seller the full purchase price of the Goods lost or damaged less any part thereof which has already been paid and until such amount has been so remitted shall hold such amount as trustee and agent for the Seller. For the avoidance of doubt the provisions of this sub-clause do not affect the Buyer's obligations under clause 6 hereof. (vi) The licences granted under sub-clauses (ii) and (iv) above shall be terminable forthwith at any time upon notice by the Seller to the Buyer. In the case of International Supply Contracts property in the Goods shall pass to the Buyer on delivery.

### 10 EXPORT

(a) If the Contract is an International Supply Contract it shall be deemed to incorporate the latest edition of Incoterms current at the date of the Contract save that in the event of any inconsistency between Incoterms and any express term of the Contract the latter shall prevail. The Seller shall be under no obligation to give the Buyer the notice specified in section 32 (3) of the Sale of Goods Act 1979.

(b) The Buyer shall be responsible for complying with any legislation or regulations governing the importation of the Goods into the country of destination and for the payment of any duties thereon.

### 11 ILLUSTRATIONS AND DESCRIPTIONS

(a) Photographs, drawings and other illustrations or descriptions contained in any catalogue, price lists, brochure or other document of the Seller shall not (save where the contrary is expressly stipulated in the order) form part of any contract between the Buyer and the Seller and on warranty is given that the goods supplied will correspond exactly with those specified.

(b) No oral statement or representation made at any time prior to the contract shall be a term of the contract or deemed to be in inducement or collateral contract pursuant to which the Buyer entered into the contract.

(c) The Seller reserves the right at any time before or after an order is placed to vary or alter or amend any particular descriptions, prices, measurements or specifications contained in its catalogue, price lists, brochures and other sales literature and such amendments and variations shall be binding upon the Buyer.

### 12 GENERAL

(a) The proper law of all contracts with the Seller shall be English law which shall govern in all respects the construction and effect of such contracts and of these conditions. The Buyer agrees that in the event of any dispute arising out of the Contract or the performance thereof he will submit to the jurisdiction of the English court.

(b) The headings to the paragraphs of these conditions are for ease of reference only and shall not affect the interpretation or construction thereof.

(c) If any provision of these conditions is or becomes illegal, void or unenforceable for any reason, the validity of the remaining provisions shall not be affected.

(d) Failure by the Seller to enforce strict compliance with these conditions by the Buyer will not constitute a waiver of any of the provisions of these conditions.

(e) Any reference in these conditions to any provision of a statute shall be construed as a reference to that provision as amended, re-enacted or extended at the relevant time. This does not affect Your statutory rights.



## Castle Brooke Tools (UK) Ltd



Princess Street  
Sheffield  
S4 7UU  
England

T: +44 (0)114 261 7200  
F: +44 (0)114 261 7370  
E: [info@castlebrooke.co.uk](mailto:info@castlebrooke.co.uk)



[www.castlebrooke.co.uk](http://www.castlebrooke.co.uk)